

SYLVANIA **SERVICE MANUAL**

**27" COLOR TELEVISION
C6427TDV**

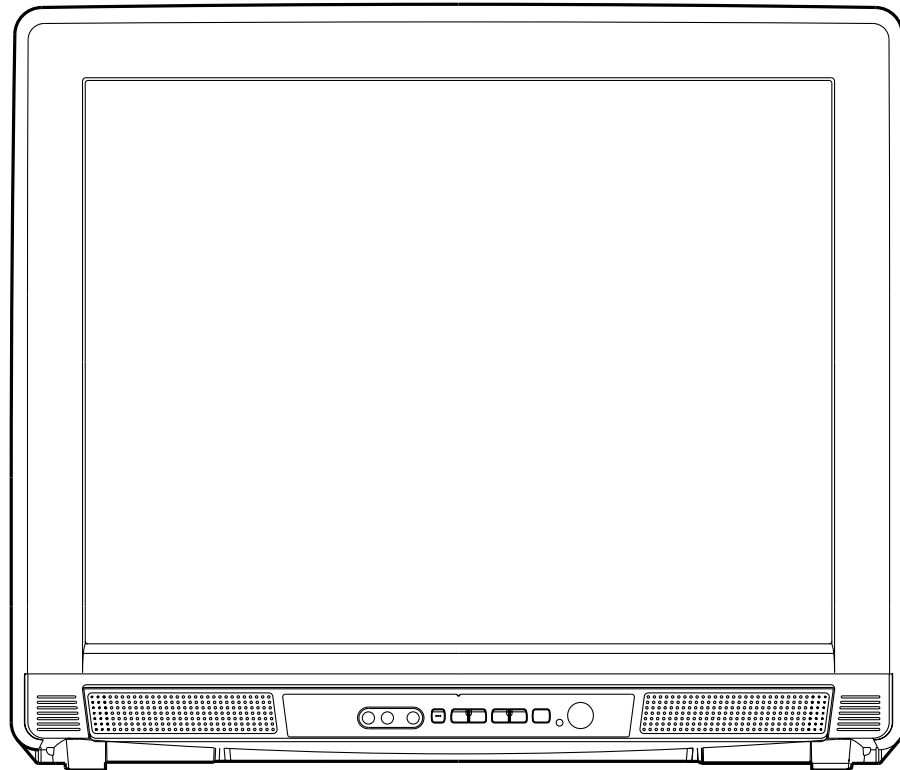

IMPORTANT SAFETY NOTICE

Proper service and repair is important to the safe, reliable operation of all Funai Equipment. The service procedures recommended by Funai and described in this service manual are effective methods of performing service operations. Some of these service special tools should be used when and as recommended.

It is important to note that this service manual contains various CAUTIONS and NOTICES which should be carefully read in order to minimize the risk of personal injury to service personnel. The possibility exists that improper service methods may damage the equipment. It also is important to understand that these CAUTIONS and NOTICES ARE NOT EXHAUSTIVE. Funai could not possibly know, evaluate and advise the service trade of all conceivable ways in which service might be done or of the possible hazardous consequences of each way. Consequently, Funai has not undertaken any such broad evaluation. Accordingly, a servicer who uses a service procedure or tool which is not recommended by Funai must first use all precautions thoroughly so that neither his safety nor the safe operation of the equipment will be jeopardized by the service method selected.

TABLE OF CONTENTS

Specifications	1-1	CBA Views and Test Points.....	7-11
Important Safety Precautions.....	2-1	Wave Forms	8-1
Standard Notes for Servicing	3-1	Wiring Diagram.....	9-1
Disassembly Instructions	4-1	IC Pin Function	10-1
Electrical Adjustment Instructions	5-1	Cabinet Exploded View	11-1
Block Diagram.....	6-1	Packing Exploded View	11-3
Schematic Diagram / CBA's and Test Points	7-1	Mechanical Parts List	12-1
Schematic Diagram	7-3	Electrical Parts List.....	13-1

SPECIFICATIONS

<TUNER>

ANT. Input ----- 75ohm Unbal., F type
 Reference Level ----- 20Vp-p (CRT Green Cathode)
 Test Input Signal ----- 400Hz 30% modulation

Description	Condition	Unit	Nominal	Limit
1. Intermediate Freq.	Picture	MHz	45.75	—
	Sound	MHz	41.25	—
2. Peak Picture Sens	VHF	dB μ v	15	30
	CATV	dB μ v	15	30
	UHF	dB μ v	15	40
3. AFT Pull In Range (10mV input)	—	MHz	\pm 2.0	\pm 0.7

<DEFLECTION>

Description	Condition	Unit	Nominal	Limit
1. Deflection Freq.	Horizontal	KHz	15.734	—
	Vertical	Hz	60	—
2. Linearity	Horizontal	%	—	\pm 15
	Vertical	%	—	\pm 10
3. Over Scan	—	%	10	—
4. High Voltage	—	KV	29	—

<VIDEO & CHROMA>

Description	Condition	Unit	Nominal	Limit
1. Misconvergence	Center	mm	—	0.4
	Side	mm	—	1.5
	Corner	mm	—	2.1
2. Brightness	APL 100%	Ft-L	25	15
3. Color Temperature	—	$^{\circ}$ K	9200 $^{\circ}$ K	—
4. Resolution	Horizontal	Line	250	—
	Vertical	Line	300	—

<AUDIO>

All items are measured across 8 Ω load at speaker output terminal.

Description	Condition	Unit	Nominal	Limit
1. Audio Output Power	10% THD	W	1	0.8
2. Audio Distortion (w/LPF)	500mW	%	2	7
3. Audio Freq. Response	-3dB	Hz	70~11K	—

Note:

Nominal specifications represent the design specifications. All units should be able to approximate these. Some will exceed and some may drop slightly below these specifications. Limit specifications represent the absolute worst condition that still might be considered acceptable. In no case should a unit fail to meet limit specifications.

IMPORTANT SAFETY PRECAUTIONS

Prior to shipment from the factory, our products are strictly inspected for recognized product safety and electrical codes of the countries in which they are to be sold. However, in order to maintain such compliance, it is equally important to implement the following precautions when a set is being serviced.

Safety Precautions for TV Circuit

1. **Before returning an instrument to the customer**, always make a safety check of the entire instrument, including, but not limited to, the following items:
 - a. Be sure that no built-in protective devices are defective and have been defeated during servicing.
 - (1) Protective shields are provided on this chassis to protect both the technician and the customer. Correctly replace all missing protective shields, including any removed for servicing convenience.
 - (2) When reinstalling the chassis and/or other assembly in the cabinet, be sure to put back in place all protective devices, including but not limited to, nonmetallic control knobs, insulating fishpapers, adjustment and compartment covers/shields, and isolation resistor/capacitor networks. **Do not operate this instrument or permit it to be operated without all protective devices correctly installed and functioning. Servicers who defeat safety features or fail to perform safety checks may be liable for any resulting damage.**
 - b. Be sure that there are no cabinet openings through which an adult or child might be able to insert their fingers and contact a hazardous voltage. Such openings include, but are not limited to, (1) spacing between the picture tube and the cabinet mask, (2) excessively wide cabinet ventilation slots, and (3) an improperly fitted and/or incorrectly secured cabinet back cover.
 - c. **Antenna Cold Check** - With the instrument AC plug removed from any AC source, connect an electrical jumper across the two AC plug prongs. Place the instrument AC switch in the on position. Connect one lead of an ohmmeter to the AC plug prongs tied together and touch the other ohmmeter lead in turn to each tuner antenna input exposed terminal screw and, if applicable, to the coaxial connector. If the measured resistance is less than 1.0 megohm or greater than 5.2 megohm, an abnormality exists that must be corrected before the instrument is returned to the customer. Repeat this test with the instrument AC switch in the off position.
 - d. **Leakage Current Hot Check** - With the instrument completely reassembled, plug the AC line cord directly into a 120V AC outlet. (Do not use an isolation transformer during this test.) Use a leak-

age current tester or a metering system that complies with American National Standards Institute (ANSI) C101.1 Leakage Current for Appliances and Underwriters Laboratories (UL) 1410, (50.7). With the instrument AC switch first in the on position and then in the off position, measure from a known earth ground (metal water pipe, conduit, etc.) to all exposed metal parts of the instrument (antennas, handle brackets, metal cabinet, screw heads, metallic overlays, control shafts, etc.), especially any exposed metal parts that offer an electrical return path to the chassis. Any current measured must not exceed 0.5 milli-ampere. Reverse the instrument power cord plug in the outlet and repeat the test.

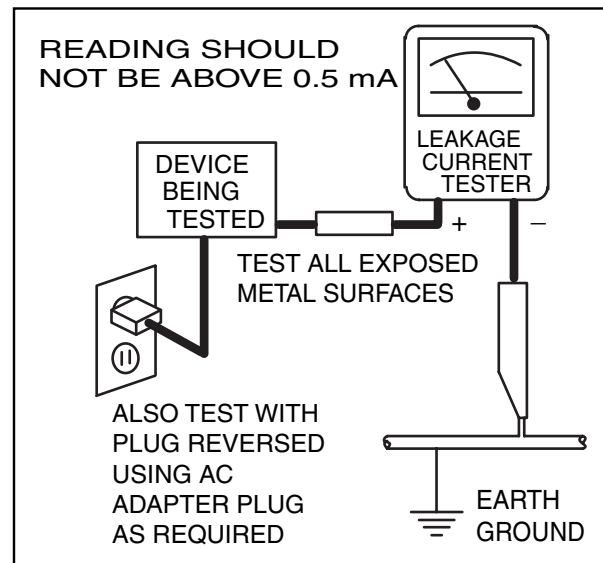

ANY MEASUREMENTS NOT WITHIN THE LIMITS SPECIFIED HEREIN INDICATE A POTENTIAL SHOCK HAZARD THAT MUST BE ELIMINATED BEFORE RETURNING THE INSTRUMENT TO THE CUSTOMER OR BEFORE CONNECTING THE ANTENNA OR ACCESSORIES.

- e. **X-Radiation and High Voltage Limits** - Because the picture tube is the primary potential source of X-radiation in solid-state TV receivers, it is specially constructed to prohibit X-radiation emissions. For continued X-radiation protection, the replacement picture tube must be the same type as the original. Also, because the picture tube shields and mounting hardware perform an X-radiation protection function, they must be correctly in place. High voltage must be measured each time servic-

ing is performed that involves B+, horizontal deflection or high voltage. Correct operation of the X-radiation protection circuits also must be reconfirmed each time they are serviced. (X-radiation protection circuits also may be called "horizontal disable" or "hold down.") Read and apply the high voltage limits and, if the chassis is so equipped, the X-radiation protection circuit specifications given on instrument labels and in the Product Safety & X-Radiation Warning note on the service data chassis schematic. High voltage is maintained within specified limits by close tolerance safety-related components/adjustments in the high-voltage circuit. If high voltage exceeds specified limits, check each component specified on the chassis schematic and take corrective action.

2. Read and comply with all caution and safety-related notes on or inside the receiver cabinet, on the receiver chassis, or on the picture tube.

3. **Design Alteration Warning** - Do not alter or add to the mechanical or electrical design of this TV receiver. Design alterations and additions, including, but not limited to circuit modifications and the addition of items such as auxiliary audio and/or video output connections, might alter the safety characteristics of this receiver and create a hazard to the user. Any design alterations or additions will void the manufacturer's warranty and may make you, the servicer, responsible for personal injury or property damage resulting therefrom.

4. **Picture Tube Implosion Protection Warning** - The picture tube in this receiver employs integral implosion protection. For continued implosion protection, replace the picture tube only with one of the same type number. Do not remove, install, or otherwise handle the picture tube in any manner without first putting on shatterproof goggles equipped with side shields. People not so equipped must be kept safely away while picture tubes are handled. Keep the picture tube away from your body. Do not handle the picture tube by its neck. Some "in-line" picture tubes are equipped with a permanently attached deflection yoke; because of potential hazard, do not try to remove such "permanently attached" yokes from the picture tube.

5. **Hot Chassis Warning** -

a. Some TV receiver chassis are electrically connected directly to one conductor of the AC power cord and maybe safety-serviced without an isolation transformer only if the AC power plug is inserted so that the chassis is connected to the ground side of the AC power source. To confirm that the AC power plug is inserted correctly, with an AC voltmeter, measure between the chassis and a known

earth ground. If a voltage reading in excess of 1.0V is obtained, remove and reinsert the AC power plug in the opposite polarity and again measure the voltage potential between the chassis and a known earth ground.

b. Some TV receiver chassis normally have 85V AC(RMS) between chassis and earth ground regardless of the AC plug polarity. This chassis can be safety-serviced only with an isolation transformer inserted in the power line between the receiver and the AC power source, for both personnel and test equipment protection.

c. Some TV receiver chassis have a secondary ground system in addition to the main chassis ground. This secondary ground system is not isolated from the AC power line. The two ground systems are electrically separated by insulation material that must not be defeated or altered.

6. Observe original lead dress. Take extra care to assure correct lead dress in the following areas:a. near sharp edges,b. near thermally hot parts-be sure that leads and components do not touch thermally hot parts,c. the AC supply,d. high voltage, and,e. antenna wiring. Always inspect in all areas for pinched, out of place, or frayed wiring. Check AC power cord for damage.

7. Components, parts, and/or wiring that appear to have overheated or are otherwise damaged should be replaced with components, parts, or wiring that meet original specifications. Additionally, determine the cause of overheating and/or damage and, if necessary, take corrective action to remove any potential safety hazard.

8. **Product Safety Notice** - Some electrical and mechanical parts have special safety-related characteristics which are often not evident from visual inspection, nor can the protection they give necessarily be obtained by replacing them with components rated for higher voltage, wattage, etc.. Parts that have special safety characteristics are identified by a (▲) on schematics and in parts lists. Use of a substitute replacement that does not have the same safety characteristics as the recommended replacement part might create shock, fire, and/or other hazards. The product's safety is under review continuously and new instructions are issued whenever appropriate. Prior to shipment from the factory, our products are strictly inspected to confirm they comply with the recognized product safety and electrical codes of the countries in which they are to be sold. However, in order to maintain such compliance, it is equally important to implement the following precautions when a set is being serviced.

Precautions during Servicing

A. Parts identified by the () symbol are critical for safety.

Replace only with part number specified.

B. In addition to safety, other parts and assemblies are specified for conformance with regulations applying to spurious radiation. These must also be replaced only with specified replacements.

Examples: RF converters, RF cables, noise blocking capacitors, and noise blocking filters, etc.

C. Use specified internal wiring. Note especially:

- 1) Wires covered with PVC tubing
- 2) Double insulated wires
- 3) High voltage leads

D. Use specified insulating materials for hazardous live parts. Note especially:

- 1) Insulation Tape
- 2) PVC tubing
- 3) Spacers
- 4) Insulators for transistors.

E. When replacing AC primary side components (transformers, power cord, etc.), wrap ends of wires securely about the terminals before soldering.

F. Observe that the wires do not contact heat producing parts (heatsinks, oxide metal film resistors, fusible resistors, etc.)

G. Check that replaced wires do not contact sharp edged or pointed parts.

H. When a power cord has been replaced, check that 5~6 kg of force in any direction will not loosen it.

I. Also check areas surrounding repaired locations.

J. Use care that foreign objects (screws, solder droplets, etc.) do not remain inside the set.

K. Crimp type wire connector

The power transformer uses crimp type connectors which connect the power cord and the primary side of the transformer. When replacing the transformer, follow these steps carefully and precisely to prevent shock hazards.

Replacement procedure

- 1) Remove the old connector by cutting the wires at a point close to the connector.
Important: Do not re-use a connector (discard it).
- 2) Strip about 15 mm of the insulation from the ends of the wires. If the wires are stranded, twist the strands to avoid frayed conductors.

3) Align the lengths of the wires to be connected. Insert the wires fully into the connector.

4) Use the crimping tool to crimp the metal sleeve at the center position. Be sure to crimp fully to the complete closure of the tool.

L. When connecting or disconnecting the internal connectors, first, disconnect the AC plug from the AC supply outlet.

Safety Check after Servicing

Examine the area surrounding the repaired location for damage or deterioration. Observe that screws, parts and wires have been returned to original positions. Afterwards, perform the following tests and confirm the specified values in order to verify compliance with safety standards.

1. Clearance Distance

When replacing primary circuit components, confirm specified clearance distance (d) and (d') between soldered terminals, and between terminals and surrounding metallic parts. (See Fig. 1)

Table 1 : Ratings for selected area

AC Line Voltage	Region	Clearance Distance (d) (d')
110 to 130 V	USA or CANADA	≥ 3.2 mm (0.126 inches)

Note: This table is unofficial and for reference only. Be sure to confirm the precise values.

2. Leakage Current Test

Confirm the specified (or lower) leakage current between B (earth ground, power cord plug prongs) and externally exposed accessible parts (RF terminals, antenna terminals, video and audio input and output terminals, microphone jacks, earphone jacks, etc.) is lower than or equal to the specified value in the table below.

Measuring Method : (Power ON)

Insert load Z between B (earth ground, power cord plug prongs) and exposed accessible parts. Use an AC voltmeter to measure across both terminals of load Z . See Fig. 2 and following table.

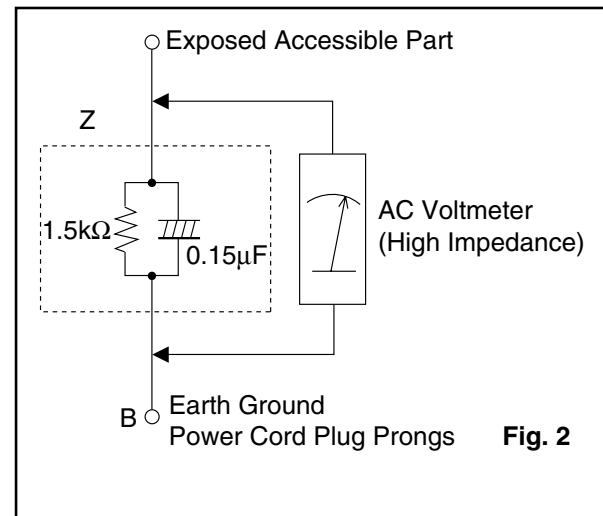
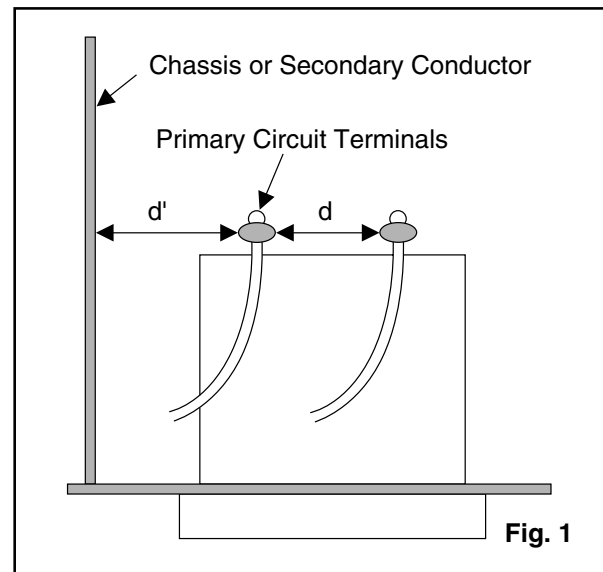

Table 2 : Leakage current ratings for selected areas

AC Line Voltage	Region	Load Z	Leakage Current (i)	Earth Ground (B) to:
110 to 130 V	USA	0.15 μ F CAP. & 1.5k Ω RES. connected in parallel	$i \leq 0.5$ mA rms	Exposed accessible parts

Note: This table is unofficial and for reference only. Be sure to confirm the precise values.

STANDARD NOTES FOR SERVICING

Circuit Board Indications

- a. The output pin of the 3 pin Regulator ICs is indicated as shown.

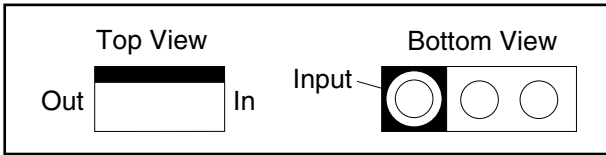

- b. For other ICs, pin 1 and every fifth pin are indicated as shown.

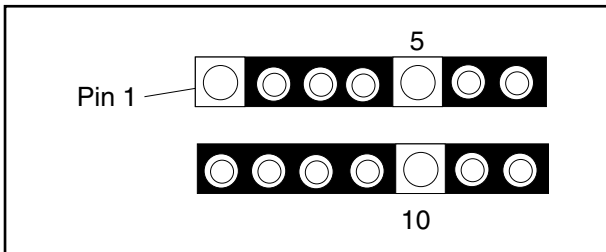

- c. The 1st pin of every male connector is indicated as shown.

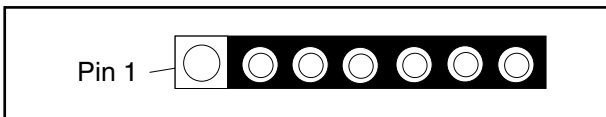

How to Remove / Install Flat Pack-IC

1. Removal

With Hot-Air Flat Pack-IC Desoldering Machine:

- (1) Prepare the hot-air flat pack-IC desoldering machine, then apply hot air to the Flat Pack-IC (about 5 to 6 seconds). (Fig. S-1-1)

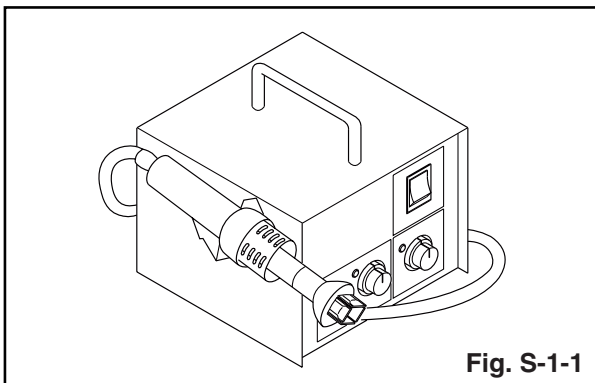

Fig. S-1-1

- (2) Remove the flat pack-IC with tweezers while applying the hot air.
- (3) Bottom of the flat pack-IC is fixed with glue to the CBA; when removing entire flat pack-IC, first apply soldering iron to center of the flat pack-IC and heat up. Then remove (glue will be melted). (Fig. S-1-6)
- (4) Release the flat pack-IC from the CBA using tweezers. (Fig. S-1-6)

Caution:

1. Do not supply hot air to the chip parts around the flat pack-IC for over 6 seconds because damage to the chip parts may occur. Put masking tape around the flat pack-IC to protect other parts from damage. (Fig. S-1-2)
2. The flat pack-IC on the CBA is affixed with glue, so be careful not to break or damage the foil of each pin or the solder lands under the IC when removing it.

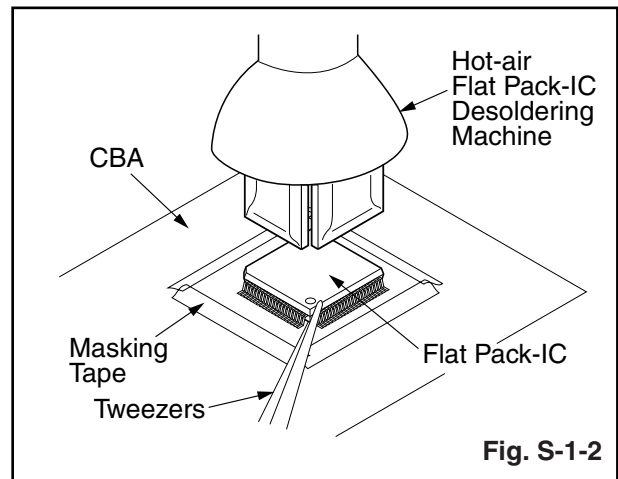
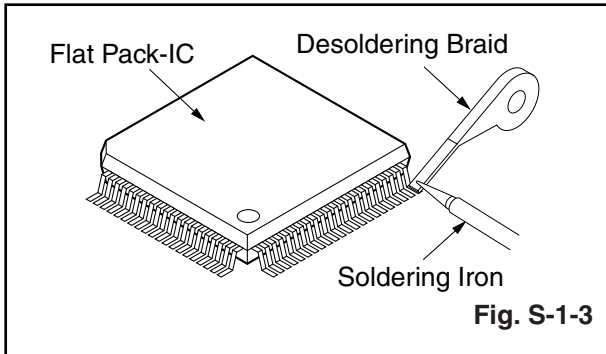

Fig. S-1-2

With Soldering Iron:

- (1) Using desoldering braid, remove the solder from all pins of the flat pack-IC. When you use solder flux which is applied to all pins of the flat pack-IC, you can remove it easily. (Fig. S-1-3)



- (2) Lift each lead of the flat pack-IC upward one by one, using a sharp pin or wire to which solder will not adhere (iron wire). When heating the pins, use a fine tip soldering iron or a hot air desoldering machine. (Fig. S-1-4)

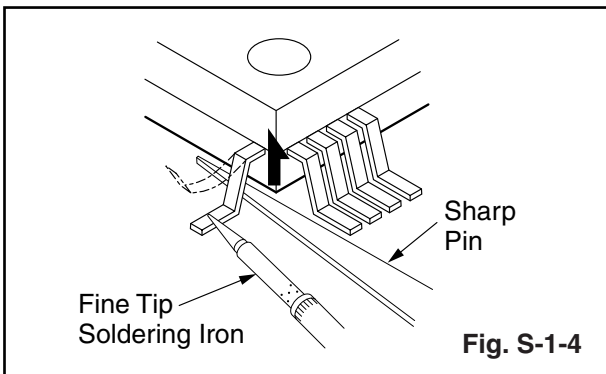

- (3) Bottom of the flat pack-IC is fixed with glue to the CBA; when removing entire flat pack-IC, first apply soldering iron to center of the flat pack-IC and heat up. Then remove (glue will be melted). (Fig. S-1-6)
- (4) Release the flat pack-IC from the CBA using tweezers. (Fig. S-1-6)

With Iron Wire:

- (1) Using desoldering braid, remove the solder from all pins of the flat pack-IC. When you use solder flux which is applied to all pins of the flat pack-IC, you can remove it easily. (Fig. S-1-3)
- (2) Affix the wire to a workbench or solid mounting point, as shown in Fig. S-1-5.
- (3) While heating the pins using a fine tip soldering iron or hot air blower, pull up the wire as the solder melts so as to lift the IC leads from the CBA contact pads as shown in Fig. S-1-5.
- (4) Bottom of the flat pack-IC is fixed with glue to the CBA; when removing entire flat pack-IC, first apply

soldering iron to center of the flat pack-IC and heat up. Then remove (glue will be melted). (Fig. S-1-6)

- (5) Release the flat pack-IC from the CBA using tweezers. (Fig. S-1-6)

Note:

When using a soldering iron, care must be taken to ensure that the flat pack-IC is not being held by glue. When the flat pack-IC is removed from the CBA, handle it gently because it may be damaged if force is applied.

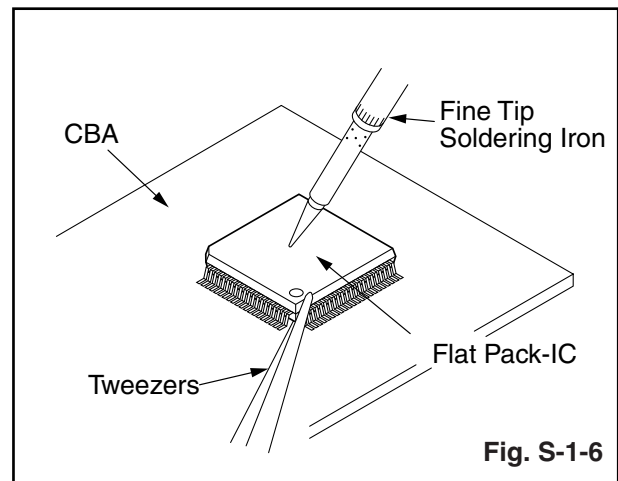
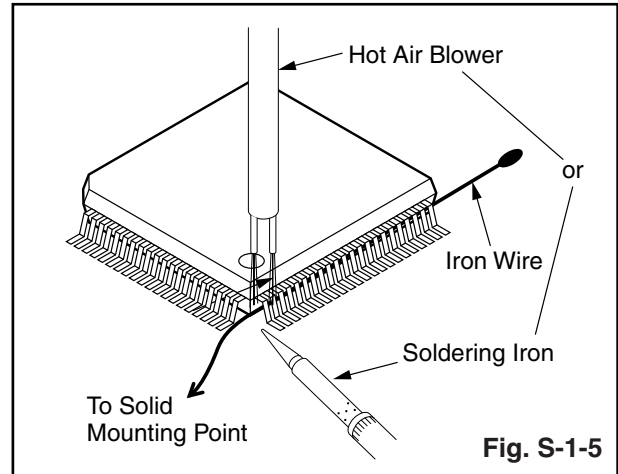

2. Installation

- (1) Using desoldering braid, remove the solder from the foil of each pin of the flat pack-IC on the CBA so you can install a replacement flat pack-IC more easily.
- (2) The "●" mark on the flat pack-IC indicates pin 1. (See Fig. S-1-7.) Be sure this mark matches the 1 on the PCB when positioning for installation. Then pre-solder the four corners of the flat pack-IC. (See Fig. S-1-8.)
- (3) Solder all pins of the flat pack-IC. Be sure that none of the pins have solder bridges.

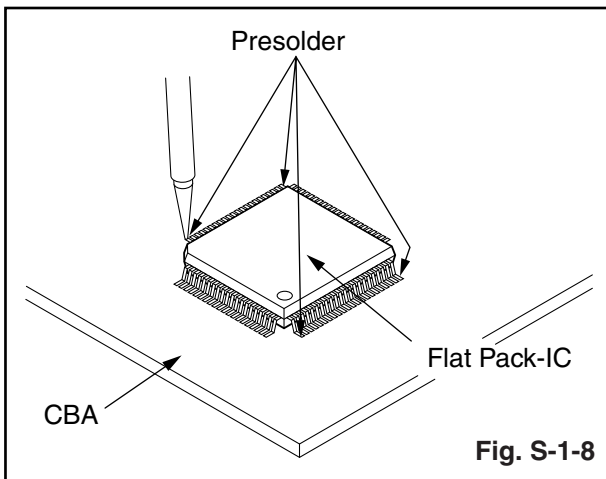
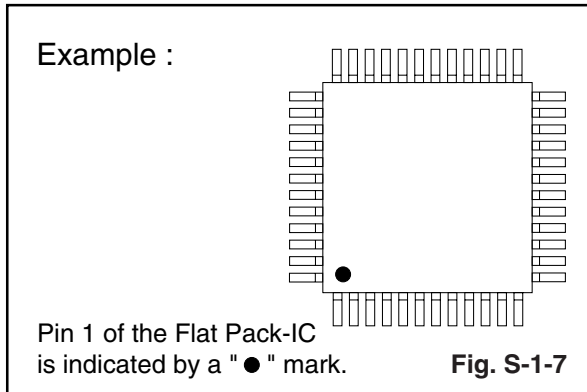

Instructions for Handling Semiconductors

Electrostatic breakdown of the semiconductors may occur due to a potential difference caused by electrostatic charge during unpacking or repair work.

1. Ground for Human Body

Be sure to wear a grounding band ($1M\Omega$) that is properly grounded to remove any static electricity that may be charged on the body.

2. Ground for Workbench

Be sure to place a conductive sheet or copper plate with proper grounding ($1M\Omega$) on the workbench or other surface, where the semiconductors are to be placed. Because the static electricity charge on clothing will not escape through the body grounding band, be careful to avoid contacting semiconductors with your clothing.

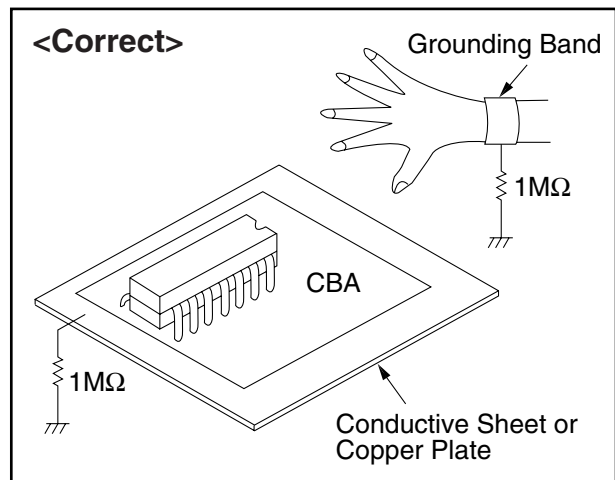
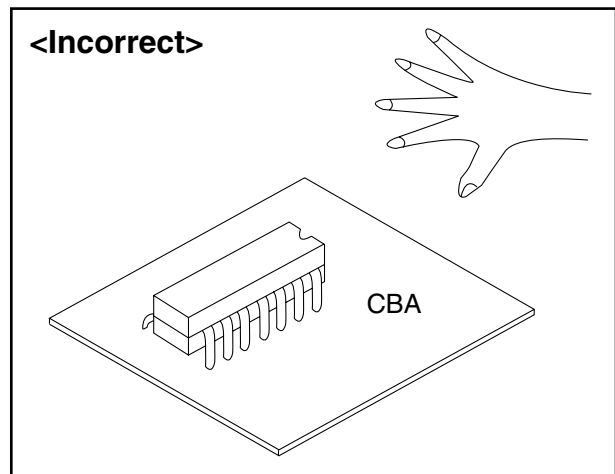

CABINET DISASSEMBLY INSTRUCTIONS

1. Disassembly Flowchart

This flowchart indicates the disassembly steps for the cabinet parts, and the CBA in order to gain access to item(s) to be serviced. When reassembling, follow the steps in reverse order. Bend, route and dress the cables as they were.

Caution !

When removing the CRT, be sure to discharge the Anode Lead of the CRT with the CRT Ground Wire before removing the Anode Cap.

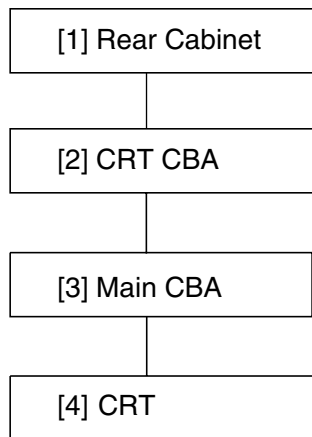

2. Disassembly Method

Step/ Loc. No.	Part	Removal		
		Fig. No	Remove/*unlock/ release/unplug/ unclamp/desolder	Note
[1]	Rear Cabinet	1,2	7(S-1), 1(S-2), 1(S-4)	1
[2]	CRT CBA	4,5	CN501	2
[3]	Main CBA	3,5	CN571	3
[4]	CRT	4	4(S-3), Anode Cap	4

↓ ↓ ↓ ↓ ↓
 (1) (2) (3) (4) (5)

Note :

- (1) Order of steps in procedure. When reassembling, follow the steps in reverse order. These numbers are also used as the Identification (location) No. of parts in figures.
- (2) Parts to be removed or installed.
- (3) Fig. No. showing procedure of part location
- (4) Identification of part to be removed, unhooked, unlocked, released, unplugged, unclamped, or desoldered.
S=Screw, P=Spring, L=Locking Tab, CN=Connector, *=Unhook, Unlock, Release, Unplug, or Desolder
2(S-2) = two Screws (S-2)
- (5) Refer to the following "Reference Notes in the Table."

Reference Notes in the Table

1. Removal of the Rear Cabinet. Remove screws 7(S-1), 1(S-2) and 1(S-4) then slide the Rear Cabinet backward.
2. Removal of the CRT CBA. Disconnect CN501 then pull the CRT CBA backward.
3. Removal of the Main CBA. Disconnect CN571 on the Main CBA then slide the Main CBA backward.

Caution:

Discharge the Anode Lead of the CRT with the CRT Ground Wire before removing the Anode Cap.

4. Removal of the CRT. Remove screws 4(S-3) and Anode Cap. then slide the CRT backward.

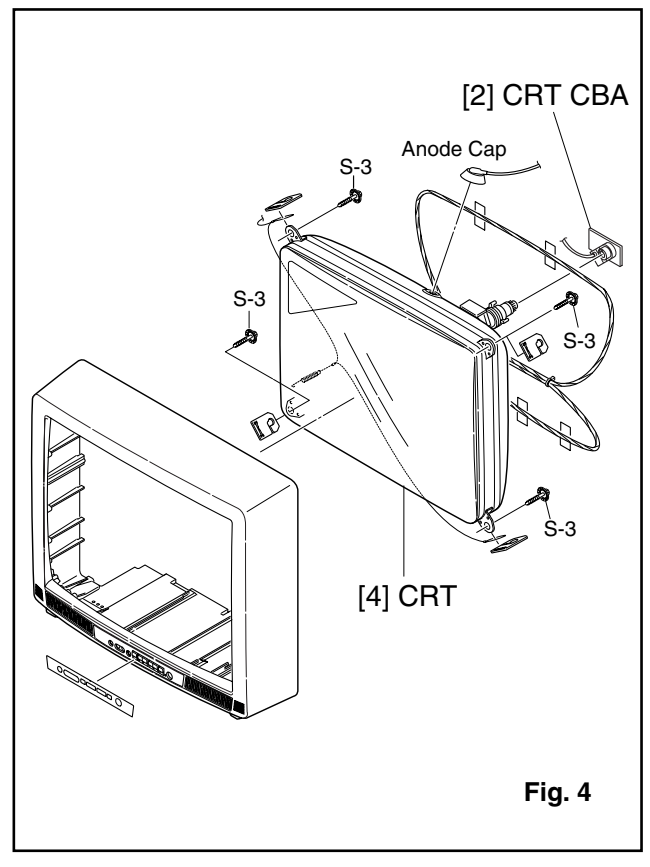
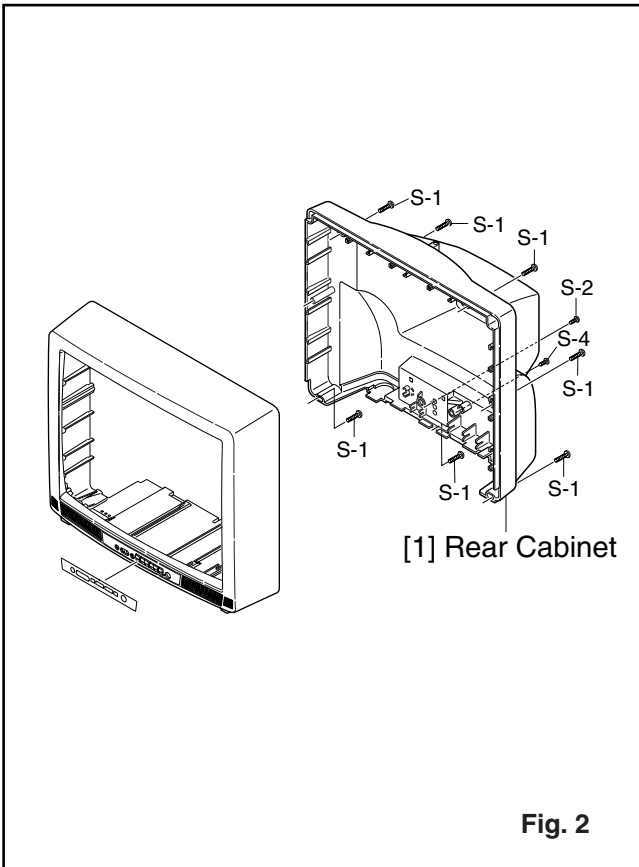
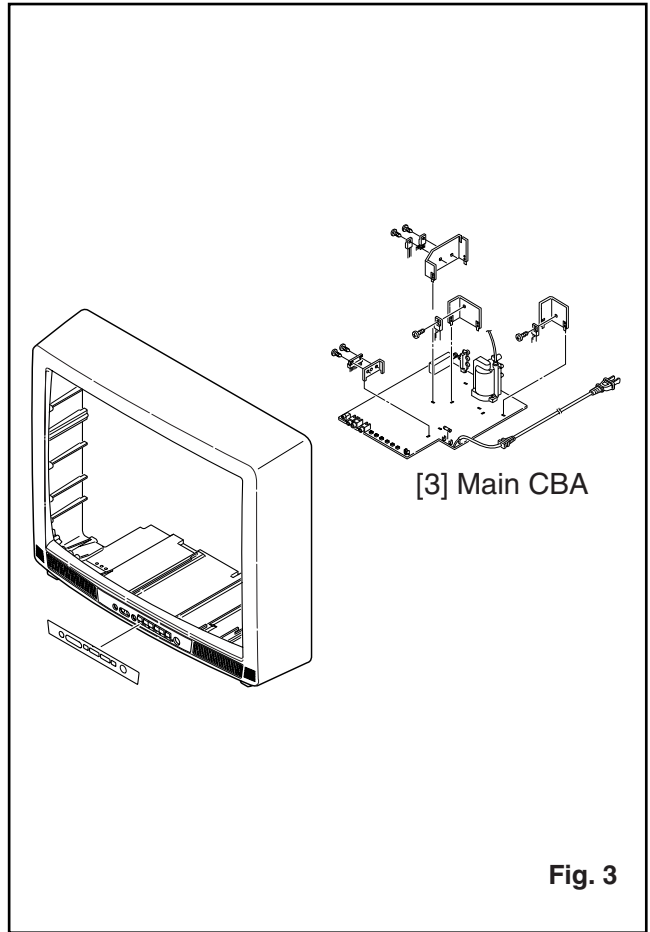
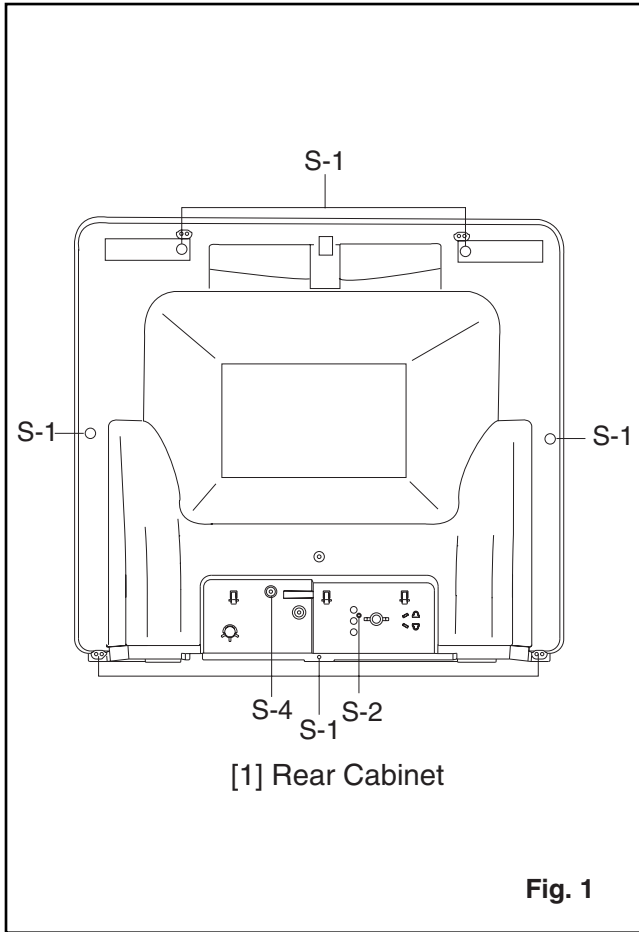

TV Cable Wiring Diagram

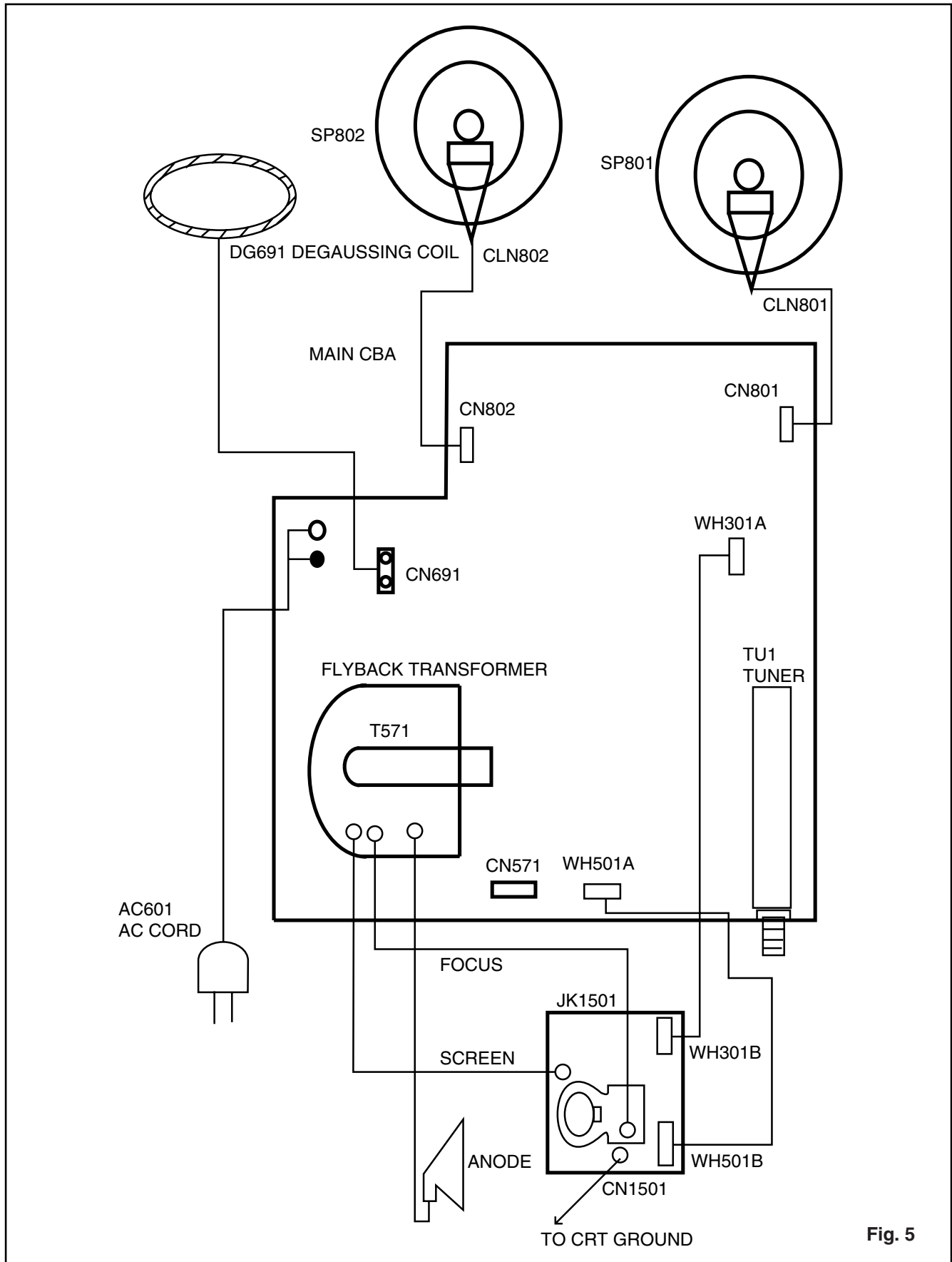

Fig. 5

ELECTRICAL ADJUSTMENT INSTRUCTIONS

General Note:

"CBA" is abbreviation for "Circuit Board Assembly."

NOTE:

Electrical adjustments are required after replacing circuit components and certain mechanical parts. It is important to perform these adjustments only after all repairs and replacements have been completed.

Also, do not attempt these adjustments unless the proper equipment is available.

Test Equipment Required

1. NTSC Pattern Generator (Color Bar W/White Window, Red Color, Dot Pattern, Gray Scale, Monoscope, Multi-Burst)
2. DC Voltmeter
3. Oscilloscope: Dual-trace with 10:1 probe, V-Range:0.001~50V/Div, F-Range: DC~AC-60MHz
4. Plastic Tip Driver
5. Remote control unit: Part No. N0138UD or N0139UD
6. DC power supply 13.2V/5A

How to make Service remote control unit:

1. Prepare normal remote control unit. (Part No. N0138UD or N0139UD) Remove 3 Screws from the back lid. (Fig. 1-1)
2. Added J1 (Jumper Wire) to the remote control CBA. (Fig. 1-2)

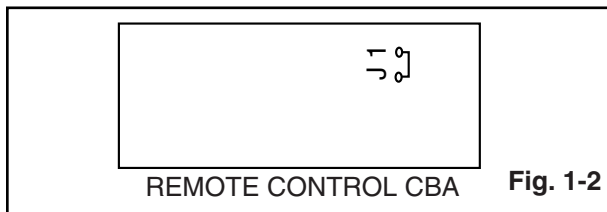
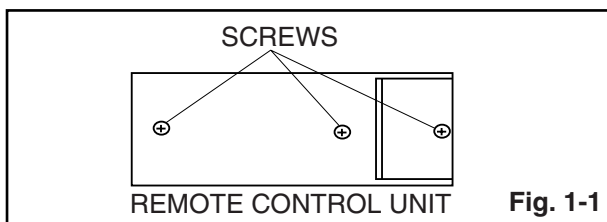

How to set up the service mode:

Service mode:

1. Use the service remote control unit.
2. Turn the power on. (Use main power on the TV unit.)
3. Press "SLEEP" button on the service remote control unit. Version of micro computer will display on the CRT. (Ex: 054-0.05)
4. Check the display on the lower left is "A501" and if it is not "A501," set it at "A501" according to "2. Initial Setting."

1. +B Adjustment

Purpose: To obtain correct operation.

Symptom of Misadjustment: The picture is dark and the unit does not operate correctly.

Test Point	Adj. Point	Mode	Input
TP601(+B) TP300(GND)	VR661	---	---
Tape	M. EQ.	Spec.	
---	DC Voltmeter	+120±0.5V DC.	

Note: TP601, TP300(GND), VR661 --- Main CBA

1. Connect DC Volt Meter to TP601 and TP300(GND).
2. Adjust VR661 so that the voltage of TP601 becomes +120±0.5V DC.

2. Initial Setting

General

1. Enter the Service mode. (See page 5-1)
2. Press "VOL ▼" button on the service remote control unit. Display changes "C/D," "7F," "LANGUAGE," "ACCESS CODE," "SOUND TYPE," "VIDEO TONE," "FM MODE," "V-OUT," "VIDEO," "AV MEMO," "STABLE SOUND," "FILTER," "300," and "YUV MEMORY" cyclically when "VOL ▼" button is pressed.
3. To set the following each data value, press "CH ▲ / ▼" buttons on the service remote control unit.

7F --- Set to "FF."

LANGUAGE --- Set to "FRA."

ACCESS CODE --- Set to "OFF."

SOUND TYPE --- Set to "ST."

VIDEO TONE --- Set to "ON."

FM-MODE --- Set to "OFF."

V-OUT --- Set to "ON."

VIDEO --- Set to "V1/V2."

AV MEMO --- Set to "OFF."

STABLE SOUND --- Set to "OFF."

FILTER --- Set to "OFF."

Adjusting the monitoring time --- Set to "500."

YUV MEMORY --- Set to "OFF."

3. Setting for BRIGHT, CONTRAST, COLOR, TINT, and SHARPNESS data Values

General

1. Enter the Service mode. (See page 5-1)
2. Press "MENU" button on the service remote control unit. Display changes "BRT," "CNT," "CLR," "S-CLR," "TNT," "V-TNT," "S-TNT," "SHARP," and "S-SRP," cyclically when "MENU" button is pressed.

CNT

1. Press "MENU" button on the service remote control unit. Then select "CONTRAST" (CNT) display.
2. Press "CH ▲/▼" buttons on the service remote control unit so that the value of "CONTRAS" (CNT) becomes 84.

CLR

1. Press "MENU" button on the service remote control unit. Then select "COLOR" (CLR) display.
2. Press "CH ▲/▼" buttons on the service remote control unit so that the value of "COLOR" (CLR) becomes 56.

S-CLR

1. Press "MENU" button on the service remote control unit. Then select "S-COLOR" (S-CLR) display.
2. Press "CH ▲/▼" buttons on the service remote control unit so that the value of "S-COLOR" (S-CLR) becomes 56.

TNT

1. Press "MENU" button on the service remote control unit. Then select "TINT" (TNT) display.
2. Press "CH ▲/▼" buttons on the service remote control unit so that the value of "TINT" (TNT) becomes 62.

V-TNT

1. Press "MENU" button on the service remote control unit. Then select "V-TINT" (V-TNT) display.
2. Press "CH ▲/▼" buttons on the service remote control unit so that the value of "V-TINT" (V-TNT) becomes 58.

S-TNT

1. Press "MENU" button on the service remote control unit. Then select "S-TINT" (S-TNT) display.
2. Press "CH ▲/▼" buttons on the service remote control unit so that the value of "S-TINT" (S-TNT) becomes 59.

SHARP

1. Press "MENU" button on the service remote control unit. Then select "SHARPNESS" (SHARP) display.
2. Press "CH ▲/▼" buttons on the service remote control unit and select "47."

S-SRP

1. Press "MENU" button on the service remote control unit. Then select "S-SHARPNESS" (S-SRP) display.
2. Press "CH ▲/▼" buttons on the service remote control unit and select "47."

4. Black Stretch Control Adjustment

Purpose: To show the fine black color.

Symptom of Misadjustment: Black color will not appear correctly.

Note: Use service remote control unit.

1. Enter the Service mode. (See page 5-1)
2. Press "6" button on the service remote control unit. "B-S" is indicated.
3. Press "CH ▲ / ▼" buttons on the service remote control unit so that display will change "OFF," "0," and "1." Then choose "B-S OFF."
4. Press "6" button on the service remote control unit. "B-S2" is indicated.
5. Press "CH ▲ / ▼" buttons on the service remote control unit so that display will change "0" and "1." Then choose "B-S2 0."
6. Turn the power off and on again, using the main power button on the TV unit.

5. Purity Check

1. Enter the Service mode. (See page 5-1)
2. Press "7" button on the remote control unit. Each time pressing 7" button on the remote control unit, display changes Red mode, Green mode, Blue mode, and White mode cyclically.
3. Select White mode.
4. Turn the power off and on again. (Main power button on the TV unit.)

6. SD Check Mode

1. Enter the Service mode. (See page 5-1)
2. Press "1" button on the remote control unit. The unit enter the SD-Check mode.
3. The unit starts selecting the added channel from first channel according to the memorized CH ADD/DELL data and CATV/TV data in RAM.

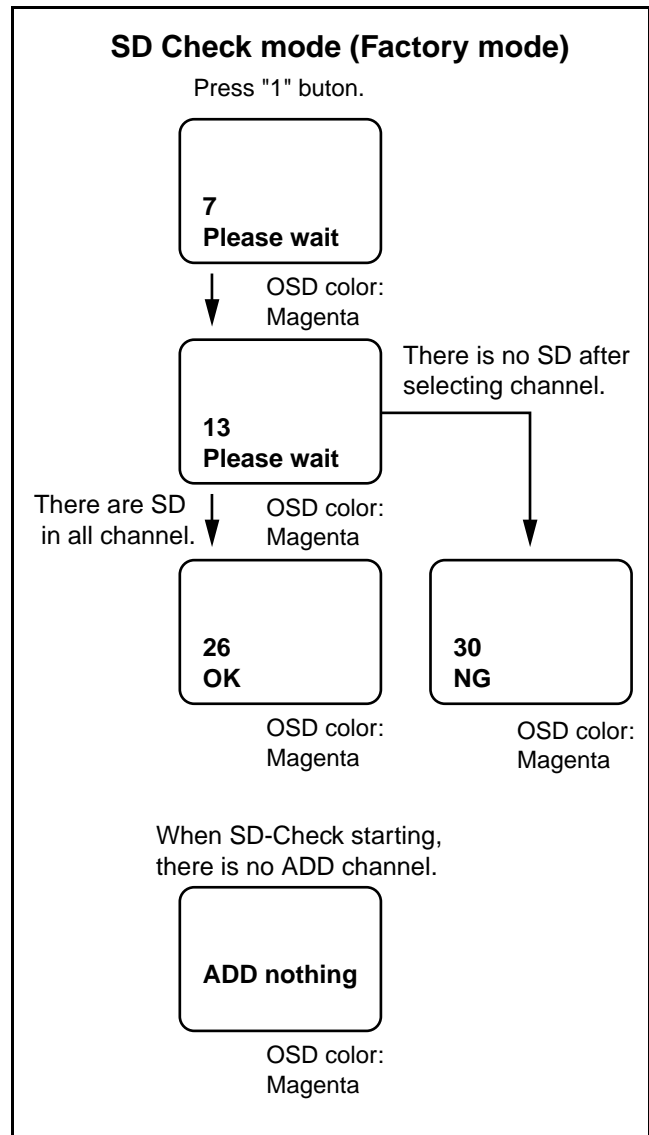

7. H. Position Adjustment

Purpose: To obtain correct horizontal position of screen image.

Symptom of Misadjustment: If H. Position is incorrect, horizontal position of image on the screen may not be properly displayed.

Test Point	Adj. Point	Mode	Input
---	CH ▲ / ▼ buttons	RF	Monoscope
Tape	M. EQ.	Spec.	
---	Monoscope	90±5%	

Note: Use service remote control unit

1. Operate the unit for at least 20 minutes.
2. Enter the Service mode. (See page 5-1)
3. Receive the monoscope pattern.
4. Press "8" button on the remote control unit. "H-P" is indicated.
5. Press "CH ▲/▼" buttons on the service remote control unit so that the monoscope pattern will be 90±5% of display size and the circle is round.
6. Turn the power off and on again. (Main power button on the TV unit.)

8. V. Size Adjustment

Purpose: To obtain correct vertical width of screen image.

Symptom of Misadjustment: If V. Size is incorrect, vertical size of image on the screen may not be properly displayed.

Test Point	Adj. Point	Mode	Input
---	CH ▲ / ▼ buttons	RF	Monoscope
Tape	M. EQ.	Spec.	
---	Monoscope	90±5%	

Note: Use service remote control unit.

1. Operate the unit for at least 20 minutes.
2. Enter the Service mode. (See page 5-1)
3. Receive the monoscope pattern.
4. Press "9" button on the service remote control unit and select "V-S" mode. (Display changes "V-S" and "V-P" cyclically when "9" button is pressed).
5. Press "CH ▲/▼" buttons on the service remote control unit so that the monoscope pattern will be 90±5% of display size and the circle is round.
6. Turn the power off and on again. (Main power button on the TV unit.)

9. V. Position Adjustment

Purpose: To obtain correct vertical width of screen image.

Symptom of misadjustment: If V. Position is incorrect, vertical height of image on the screen may not be properly displayed.

Test Point	Adj. Point	Mode	Input
---	CH ▲ / ▼ buttons	RF	Monoscope
Tape	M. EQ.	Spec.	
---	Monoscope	See below.	

Note: Use service remote control unit

1. Operate the unit for at least 20 minutes.
2. Enter the Service Mode. (See page 5-1)
3. Receive the monoscope pattern.
4. Press "9" button on the service remote control unit and select "V-P" mode. (Display change "V-S" and "V-P" cyclically when "9" button is pressed).
5. Press "CH ▲/▼" buttons on the service remote control unit so that the top and bottom of the monoscope pattern will be equal of each other.
6. Turn the power off and on again. (Main power button on the TV unit.)

10. Software Reset

To reset software, press "5" button on the remote control unit for at least 5 seconds after pressing "CH RETURN" button on the remote control unit.

11. Cut-off Adjustment

Purpose: To adjust the beam current of R, G, B, and screen voltage.

Symptom of Misadjustment: White color may be reddish, greenish or bluish.

Test Point	Adj. Point	Mode	Input
---	Screen-Control CH ▲ / ▼ buttons	RF	Black Raster
Tape	M. EQ.	Spec.	
---	Pattern Generator	See Reference Notes below.	

Figure

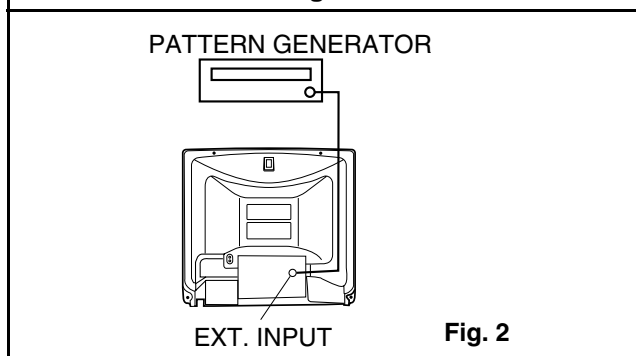

Fig. 2

Note: Screen Control FBT --- Main CBA
F.B.T= Fly Back Transformer
Use service remote control unit

1. Degauss the CRT and allow CRT to operate for 20 minutes before starting the alignment.
2. Input the Black Raster Signal from RF Input.
3. Enter the Service mode. (See page 5-1)
4. Press "VOL ▼" button on the service remote control unit and select "C/D" mode. (Display changes "C/D," "7F," "LANGUAGE," "ACCESS CODE," "SOUND TYPE," "VIDEO TONE," "FM MODE," "V-OUT," "VIDEO," "AV MEMO," "STABLE SOUND," "FILTER," "500," and "YUV MEMORY" cyclically when "VOL ▼" button is pressed.) then press "1." The display will momentarily show "CUT OFF R" (R= Red). Now there should be a horizontal line across the center of the picture tube. If needed gradually turn the screen control on the fly-back, clockwise until the horizontal line appears. Adjust the Red Cut off by pressing the "CH ▲/▼" buttons. Proceed to Step 5 when the Red Cut off adjustment is done.
5. Press the "2" button. The display will momentarily show "CUT OFF G" (G=Green). Adjust the Green Cut off by pressing the "CH ▲/▼" buttons. Proceed to step 6 when the Green Cut off adjustment is done.
6. Press the "3" button. The display will momentarily show "CUT OFF B" (B=Blue). Adjust the Blue cut off by pressing the "CH ▲/▼" buttons. When done with steps 4, 5 and 6 the horizontal line should be pure white if not, then attempt the Cut off adjustment again.

12. White Balance Adjustment

Purpose: To mix red, green and blue beams correctly for pure white.

Symptom of Misadjustment: White becomes bluish or reddish.

Test Point	Adj. Point	Mode	Input
Screen	CH ▲ / ▼ buttons	RF	White Raster (APL 100%)
Tape	M. EQ.	Spec.	
---	Pattern Generator, Color analyzer	See below	

Figure

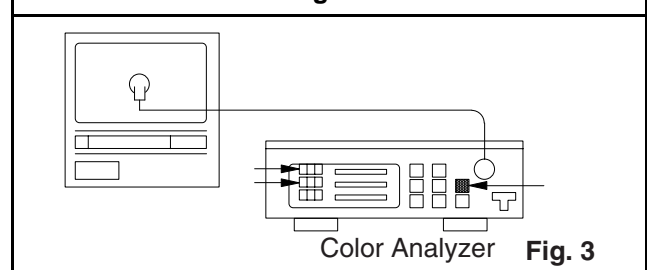

Fig. 3

Note: Use service remote control unit

1. Operate the unit more than 20 minutes.
2. Face the unit to east. Degauss the CRT using Degaussing Coil.
3. Input the White Raster (APL 100%).
4. Set the color analyzer to the CHROMA mode and after zero point calibration, bring the optical receptor to the center on the tube surface (CRT).
5. Enter the Service mode. Press "VOL ▼" button on the service remote control unit and select "C/D" mode. (Display changes "C/D," "7F," "LANGUAGE," "ACCESS CODE," "SOUND TYPE," "VIDEO TONE," "FM MODE," "V-OUT," "VIDEO," "AV MEMO," "STABLE SOUND," "FILTER," "500," and "YUV MEMORY" cyclically when "VOL ▼" button is pressed.) then Press No. 8 button on the service remote control Unit.
6. Press No. 4 button on the service remote control unit for Red adjustment. Press NO. 5 button on the service remote control unit for Blue adjustment.
7. In each color mode, Press "CH ▲/▼" button to adjust the values of color.
8. Adjusting Red and Blue color so that the temperature becomes 9200K (x: 286 / y: 294)±3%.
9. At this time, Re-check that Horizontal line is white. If not, Re-adjust Cut-off Adjustment until the Horizontal Line becomes pure white.
10. Turn off and on again to return to normal mode. Receive APL 100% white signal and Check Chroma temperatures become 9200K (x: 286 / y: 294)±3%.

Note: Confirm that Cut Off Adj. is correct after this adjustment, and attempt Cut Off Adj. if needed.

13. Sub-Brightness Adjustment

Purpose: To get proper brightness.

Symptom of Misadjustment: If Sub-Brightness is incorrect, proper brightness cannot be obtained by adjusting the Brightness Control.

Test Point	Adj. Point	Mode	Input
---	CH ▲ / ▼ buttons	RF	IQW
Tape	M. EQ.	Spec.	
---	Pattern Generator	See below	

Figure

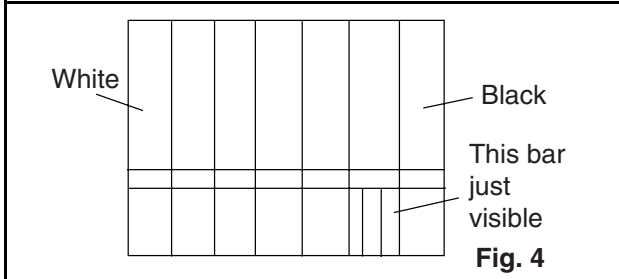

Note: IQW Setup level --- 7.5 IRE

Use service remote control unit

1. Enter the Service mode. (See page 5-1)
Then input IQW signal from RF Input.
2. Press "MENU" button on the service remote control unit and Select "BRT" mode. (Display changes "BRT," "CNT," "CLR," "S-CLR," "C-CLR," "TNT," "V-TNT," "S-TNT," "C-TNT," "SHARP," "S-SRP," and "C-SRP" cyclically when "MENU" button is pressed). Press "CH ▲/▼" buttons so that the bar is just visible (See above figure).
3. Turn the power off and on again. (Main power button on the TV unit.)

14. Focus Adjustment

Purpose: Set the optimum Focus.

Symptom of Misadjustment: If Focus Adjustment is incorrect, blurred images are shown on the display.

Test Point	Adj. Point	Mode	Input
---	Focus Control	---	Monoscope
Tape	M. EQ.	Spec.	
---	Pattern Generator	See below	

Note: Focus VR (FBT) - Main CBA,
FBT=Fly Back Transformer

1. Operate the unit more than 30 minutes.
2. Face the unit to the East and Degauss the CRT using Degaussing Coil.
3. Input the Monoscope Pattern.
4. Adjust the Focus Control on the FBT to obtain clear picture.

The following adjustments normally are not attempted in the field. Only when replacing the CRT then adjust as a preparation.

15. Purity Adjustment

Purpose: To obtain pure color.

Symptom of Misadjustment: If Color Purity Adjustment is incorrect, large areas of color may not be properly displayed.

Test Point	Adj. Point	Mode	Input
---	Deflection Yoke Purity Magnet	---	Red Color
Tape	M. EQ.	Spec.	
---	Pattern Generator	See below.	

Figure

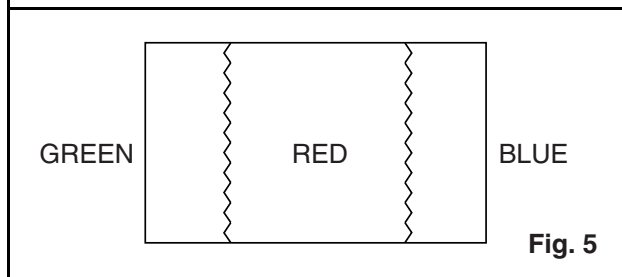

1. Set the unit facing east.
2. Operate the unit for over 30 minutes before adjusting.
3. Fully degauss the unit using an external degaussing coil.
4. Loosen the screw on the Deflection Yoke Clamper and pull the Deflection Yoke back away from the screen. (See Fig. 6)
5. Loosen the Ring Lock and adjust the Purity Magnets so that a red field is obtained at the center of the screen. Tighten Ring Lock. (See Fig. 5,6)
6. Slowly push the Deflection Yoke toward bell of CRT and set it where a uniform red field is obtained.
7. Tighten the clamp screw on the Deflection Yoke.

16. Convergence Adjustment

Purpose: To obtain proper convergence of red, green and blue beams.

Symptom of Misadjustment: If Convergence Adjustment is incorrect, the edge of white letters may have color edges.

Test Point	Adj. Point	Mode	Input
---	C.P. Magnet (RB, C.P. Magnet (RB-G, Deflection Yoke	---	Dot Pattern or Crosshatch
Tape	M. EQ.	Spec.	
---	Pattern Generator	See below.	

Figure

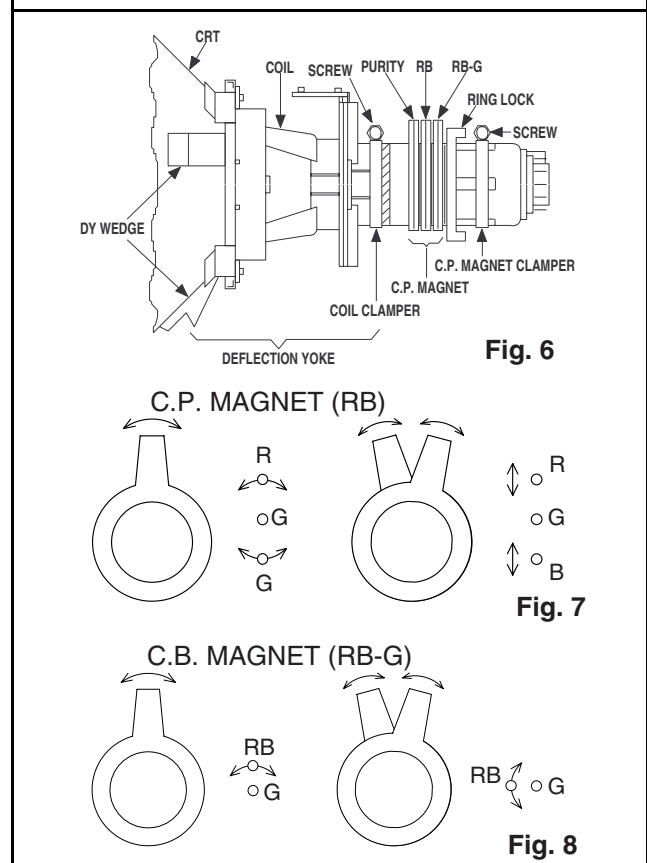

1. Loosen the Ring Lock and align red with blue dots or Crosshatch at the center of the screen by rotating (RB) C.P. Magnets. (See Fig. 7)
2. Align red / blue with green dots at the center of the screen by rotating (RB-G) C.P. Magnet. (See Fig. 8)
3. Fix the C.P. Magnets by tightening the Ring Lock.
4. Remove the DY Wedges and slightly tilt the Deflection Yoke horizontally and vertically to obtain the best overall convergence.
5. Fix the Deflection Yoke by carefully inserting the DY Wedges between CRT and Deflection Yoke.

BLOCK DIAGRAMS

System Control Block Diagram

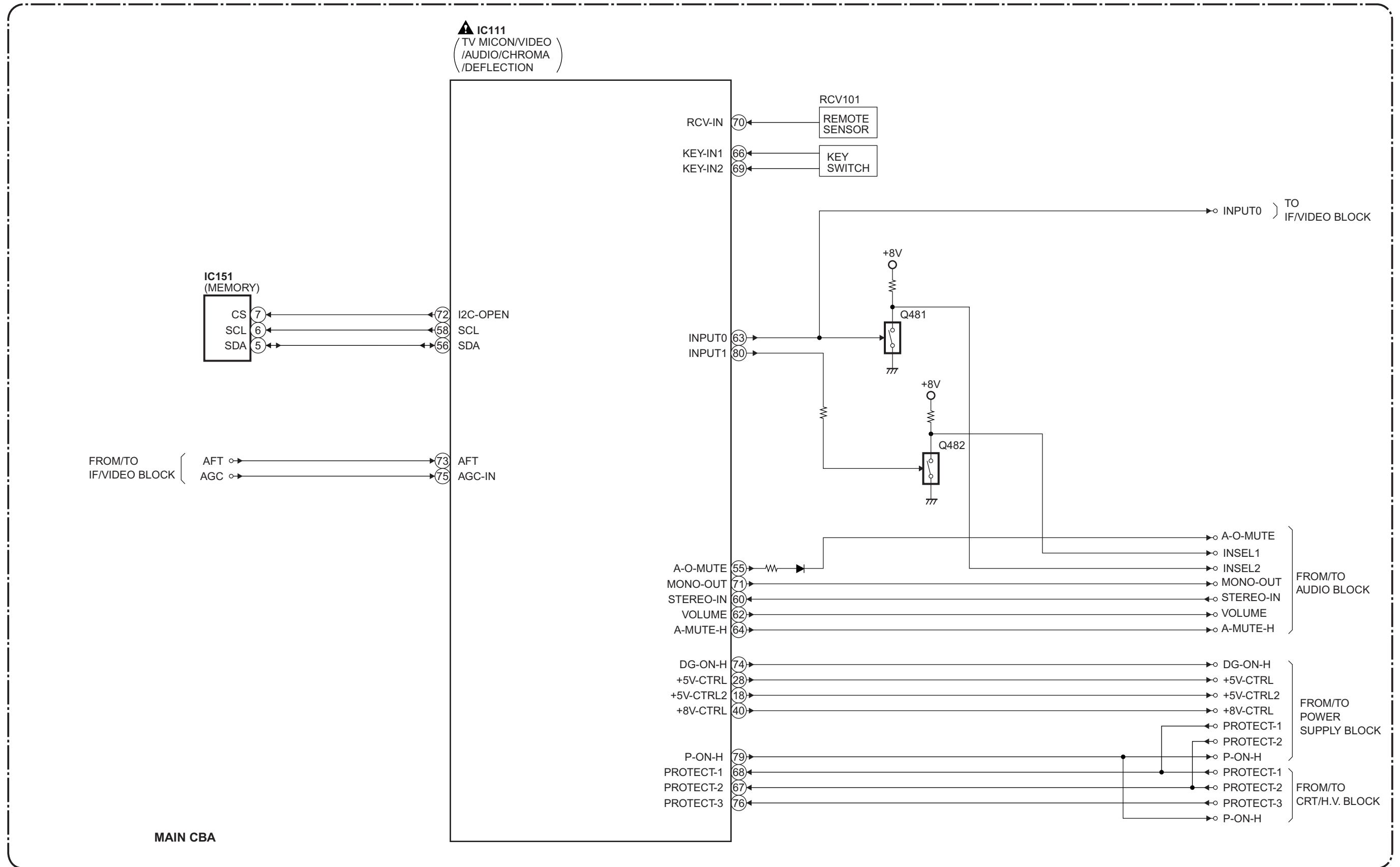

IF/Video Block Diagram

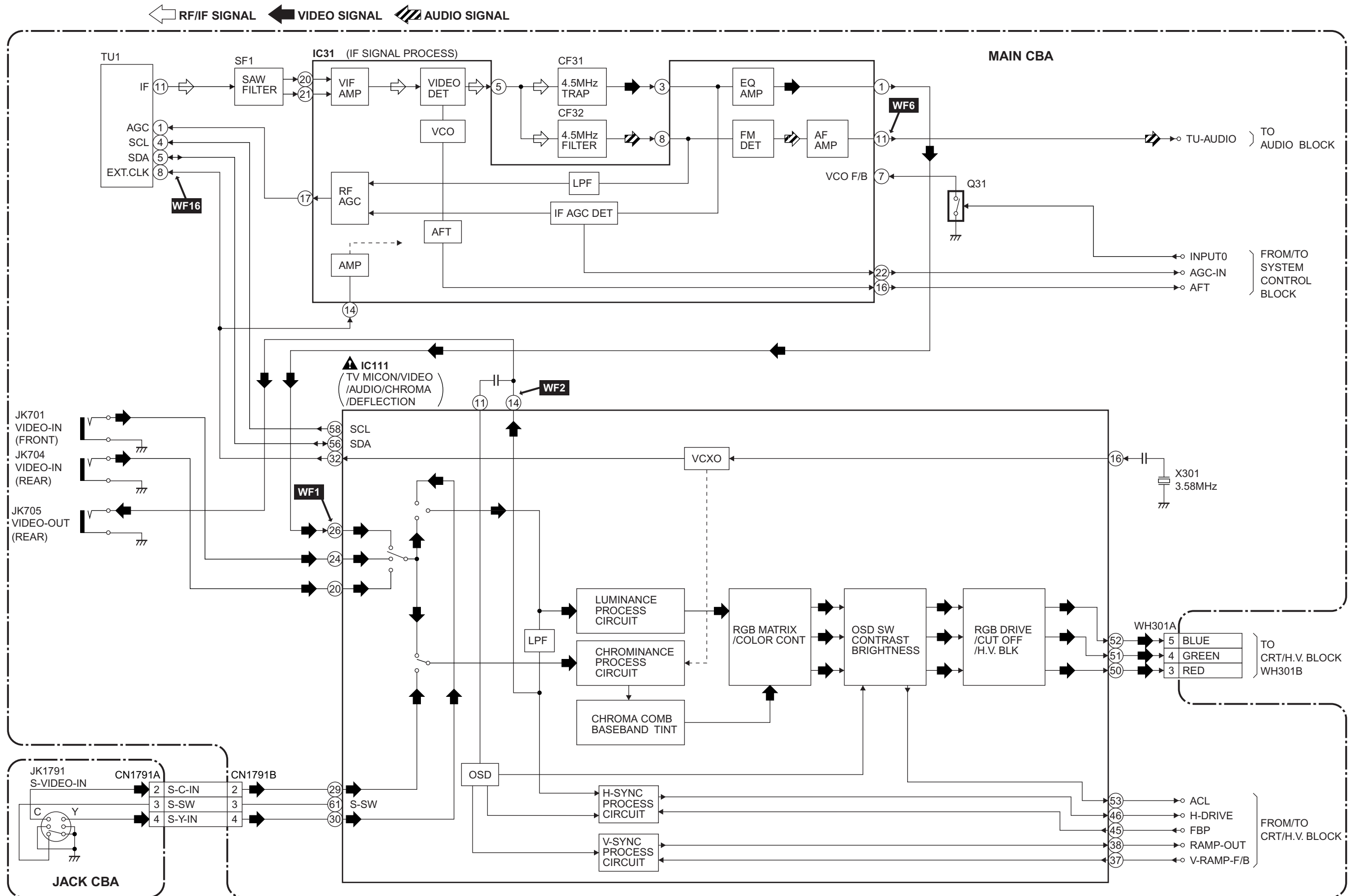

Audio Block Diagram

AUDIO SIGNAL

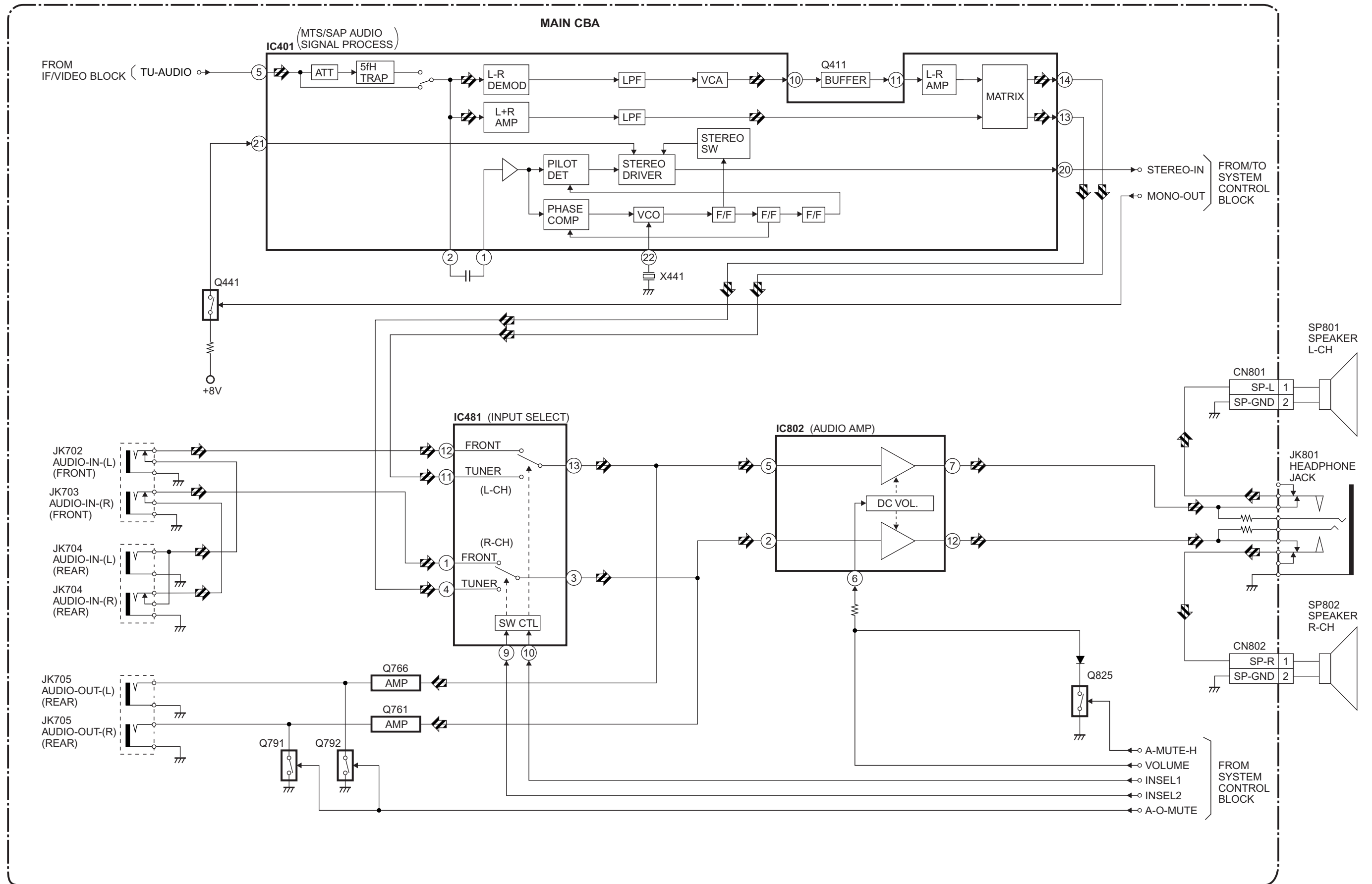

CRT/H.V. Block Diagram

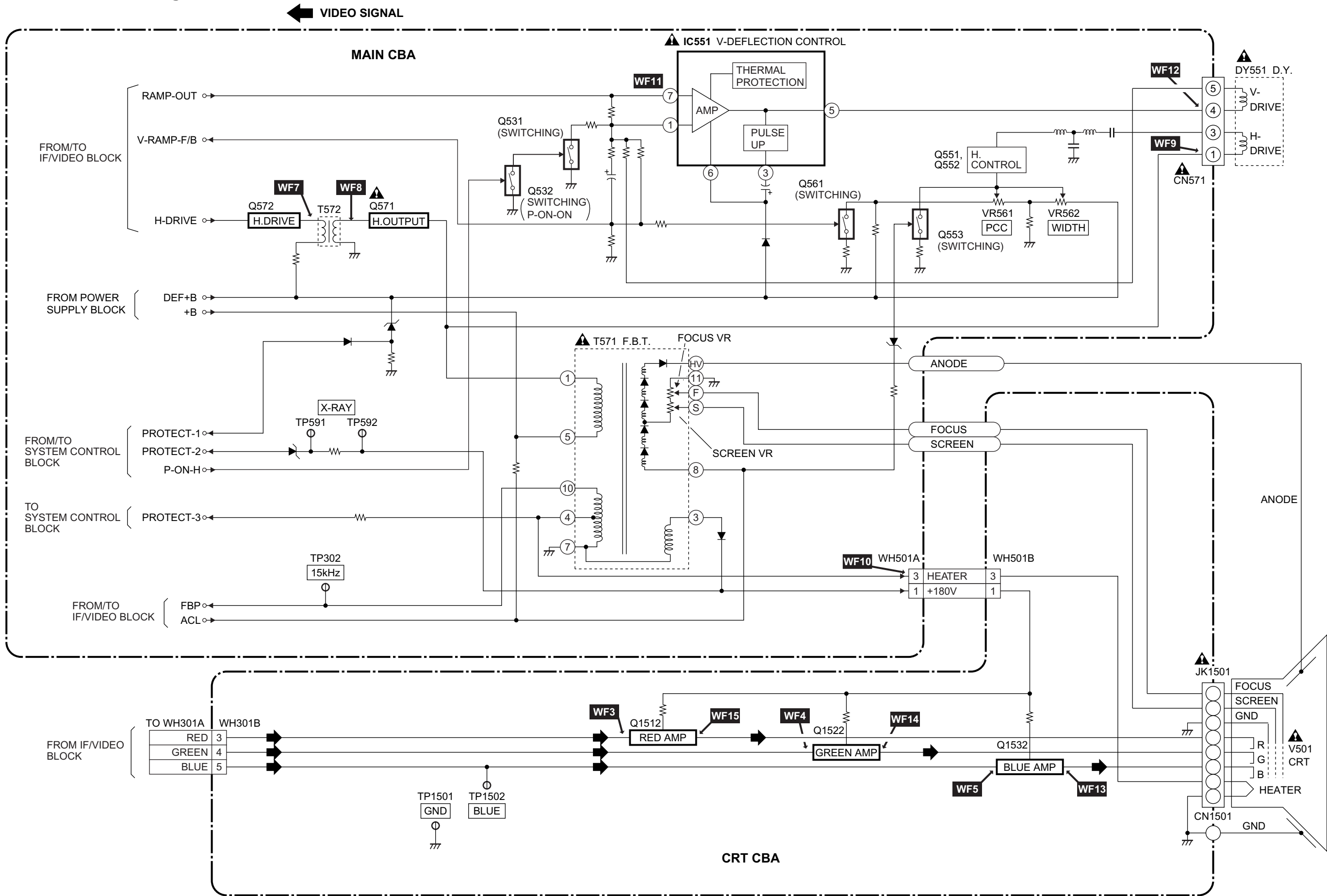

Power Supply Block Diagram

CAUTION !

Fixed voltage (or Auto voltage selectable) power supply circuit is used in this unit. If Main Fuse (F601) is blown, check to see that all components in the power supply circuit are not defective before you connect the AC plug to the AC power supply. Otherwise it may cause some components in the power supply circuit to fail.

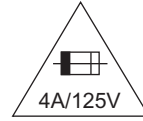

CAUTION: FOR CONTINUED PROTECTION AGAINST RISK OF FIRE, REPLACE ONLY WITH SAME TYPE 4 A, 125V FUSE.
ATTENTION: UTILISER UN FUSIBLE DE RECHANGE DE MÊME TYPE DE 4A, 125V.

NOTE :
 The voltage for parts in hot circuit is measured using hot GND as a common terminal.

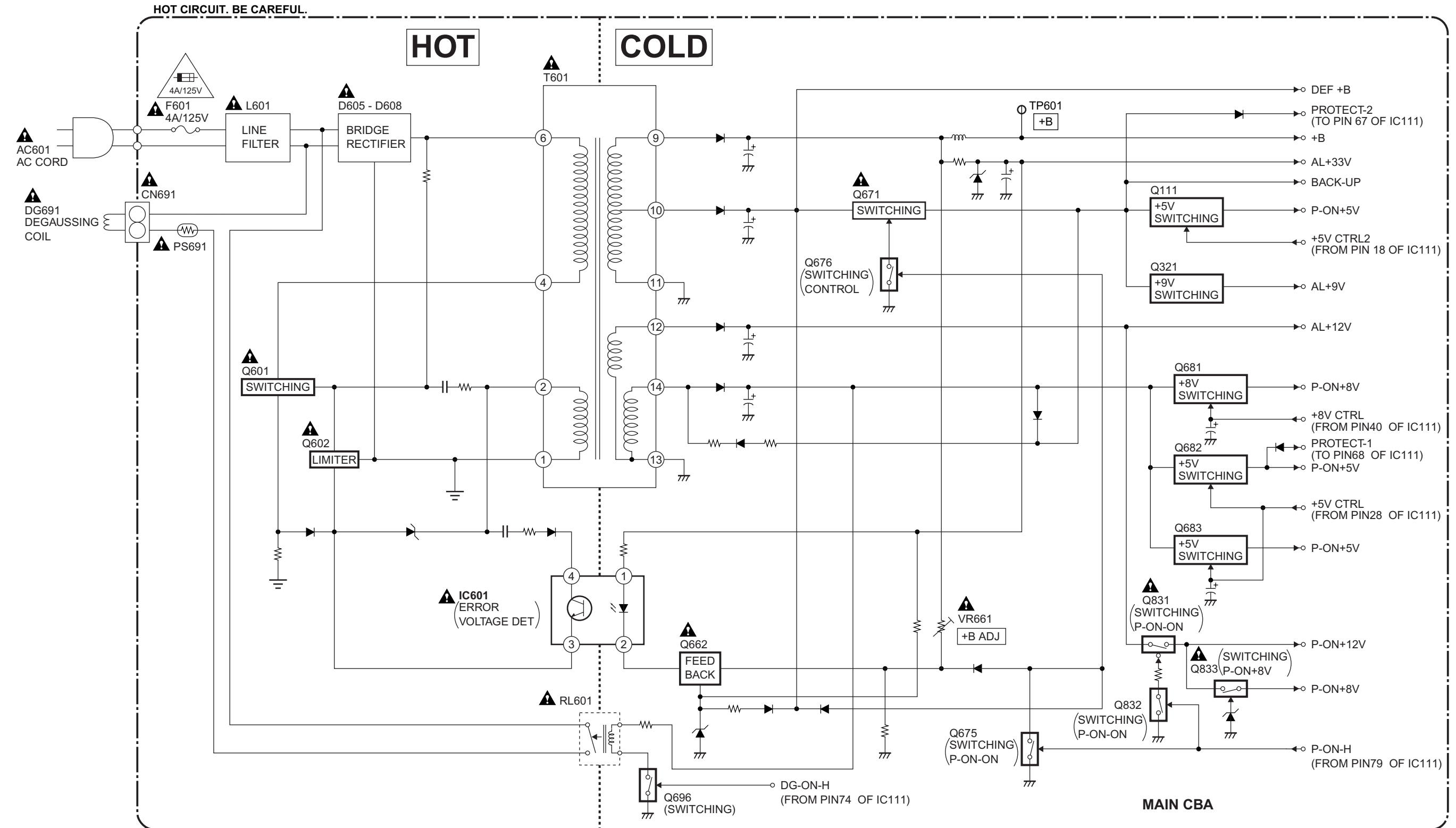

SCHEMATIC DIAGRAMS / CBA'S AND TEST POINTS

Standard Notes

Many electrical and mechanical parts in this chassis have special characteristics. These characteristics often pass unnoticed and the protection afforded by them cannot necessarily be obtained by using replacement components rated for higher voltage, wattage, etc. Replacement parts that have these special safety characteristics are identified in this manual and its supplements; electrical components having such features are identified by the mark "▲" in the schematic diagram and the parts list. Before replacing any of these components, read the parts list in this manual carefully. The use of substitute replacement parts that do not have the same safety characteristics as specified in the parts list may create shock, fire, or other hazards.

Note:

1. Do not use the part number shown on these drawings for ordering. The correct part number is shown in the parts list, and may be slightly different or amended since these drawings were prepared.
2. All resistance values are indicated in ohms ($K=10^3$, $M=10^6$).
3. Resistor wattages are 1/4W or 1/6W unless otherwise specified.
4. All capacitance values are indicated in μF ($P=10^{-6}\mu F$).
5. All voltages are DC voltages unless otherwise specified.

Note of Capacitors:

ML --- Mylar Cap. PP --- Metallized Film Cap. SC --- Semiconductor Cap. L --- Low Leakage type

Temperature Characteristics of Capacitors are noted with the following:

B --- $\pm 10\%$ CH --- $0 \pm 60 \text{ ppm}/^\circ\text{C}$ CSL --- $+350 \sim -1000 \text{ ppm}/^\circ\text{C}$

Tolerance of Capacitors are noted with the following:

Z --- $+80 \sim -20\%$

Note of Resistors:

CEM --- Cement Res. MTL --- Metal Res. F --- Fuse Res.

Capacitors and transistors are represented by the following symbols.

CBA Symbols

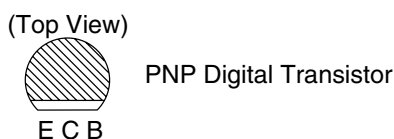
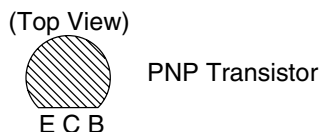
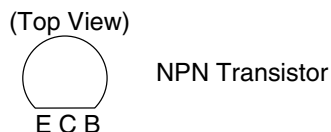
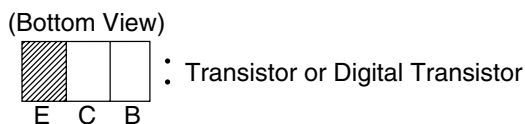
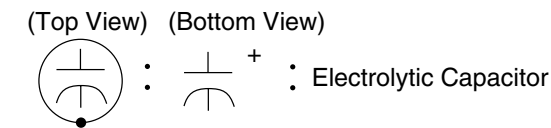

Schematic Diagram Symbols

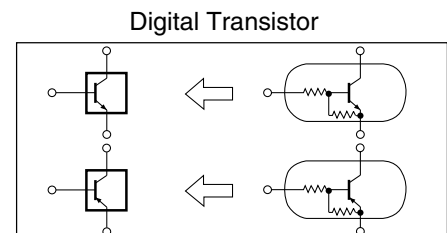

LIST OF CAUTION, NOTES, AND SYMBOLS USED IN THE SCHEMATIC DIAGRAMS ON THE FOLLOWING PAGES:

1. CAUTION: FOR CONTINUED PROTECTION AGAINST RISK OF FIRE, REPLACE ONLY WITH SAME TYPE_A,_V FUSE.

ATTENTION: UTILISER UN FUSIBLE DE RECHANGE DE MÊME TYPE DE_A,_V.

2. CAUTION:

Fixed Voltage (or Auto voltage selectable) power supply circuit is used in this unit.

If Main Fuse (F601) is blown, first check to see that all components in the power supply circuit are not defective before you connect the AC plug to the AC power supply. Otherwise it may cause some components in the power supply circuit to fail.

3. Note:

(1) Do not use the part number shown on the drawings for ordering. The correct part number is shown in the parts list, and may be slightly different or amended since the drawings were prepared.

(2) To maintain original function and reliability of repaired units, use only original replacement parts which are listed with their part numbers in the parts list section of the service manual.

4. Wire Connectors

(1) Prefix symbol "CN" means "connector" (can disconnect and reconnect).

(2) Prefix symbol "CL" means "wire-solder holes of the PCB" (wire is soldered directly).

5. Note: Mark "●" is a leadless (chip) component.

6. Voltage indications on the schematics are as shown below:

Plug the TV power cord into a standard AC outlet.:

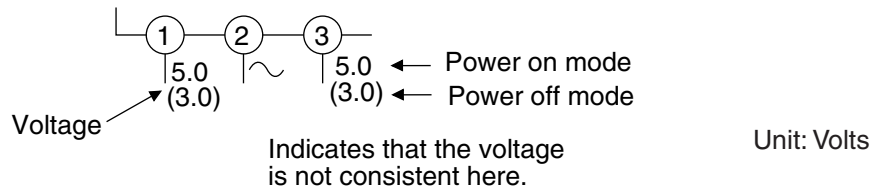

7. How to read converged lines

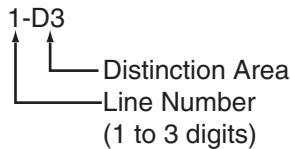

Examples:

1. "1-D3" means that line number "1" goes to area "D3".

2. "1-B1" means that line number "1" goes to area "B1".

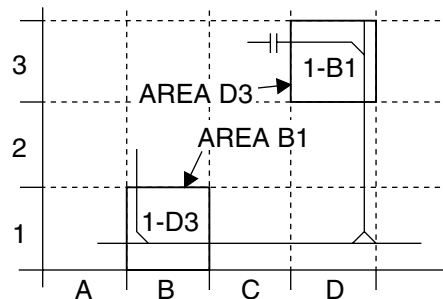

8. Test Point Information

⊕ : Indicates a test point with a jumper wire across a hole in the PCB.

□→ : Used to indicate a test point with a component lead on foil side.

⊘ : Used to indicate a test point with no test pin.

● : Used to indicate a test point with a test pin.

Main 1/4 Schematic Diagram

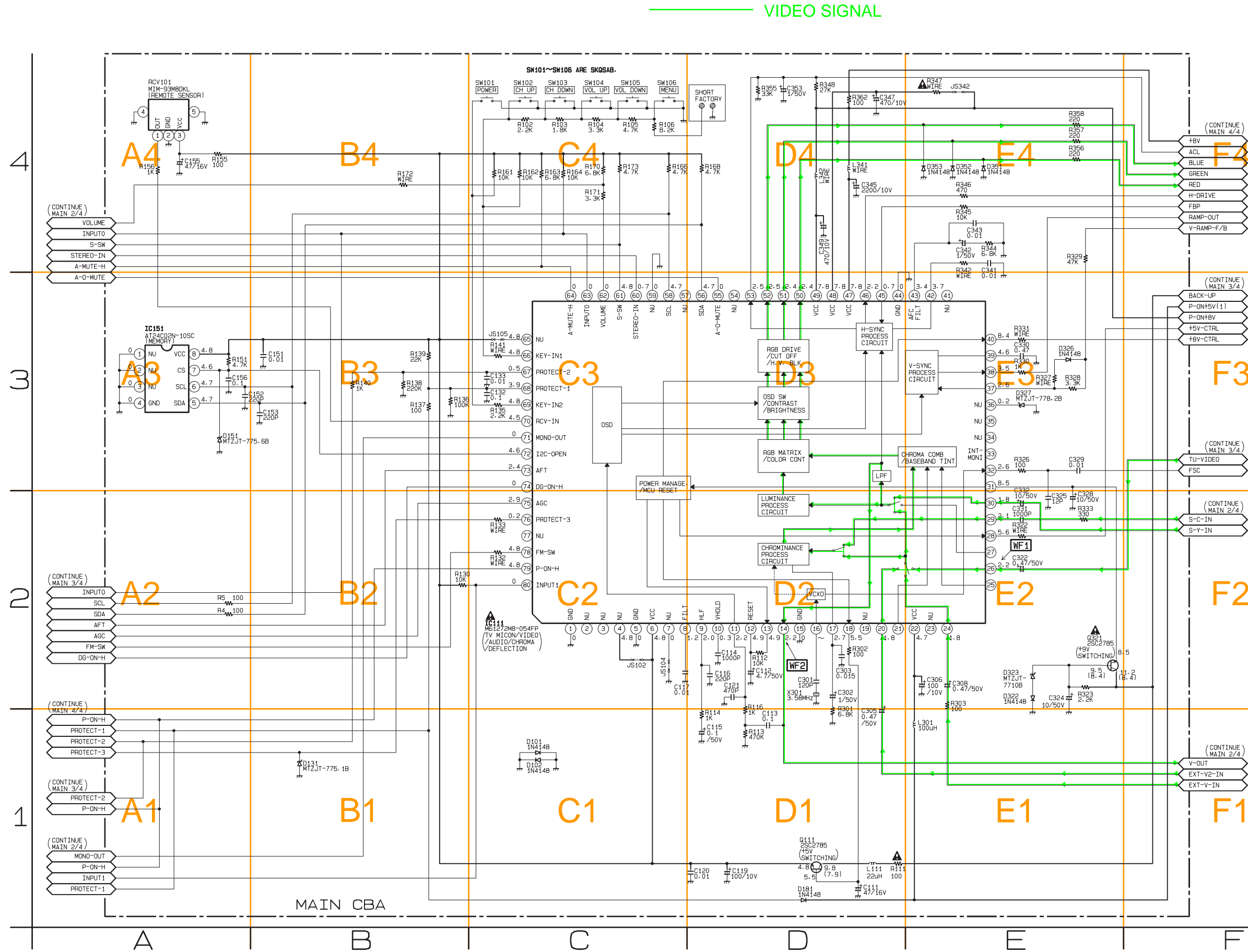

MAIN 1/4

Ref No.	Position
ICS	
IC111	C-2
IC151	A-3
TRANSISTORS	
Q111	D-1
Q321	E-2

Main 2/4 & Jack Schematic Diagram

→ VIDEO SIGNAL
← AUDIO SIGNAL

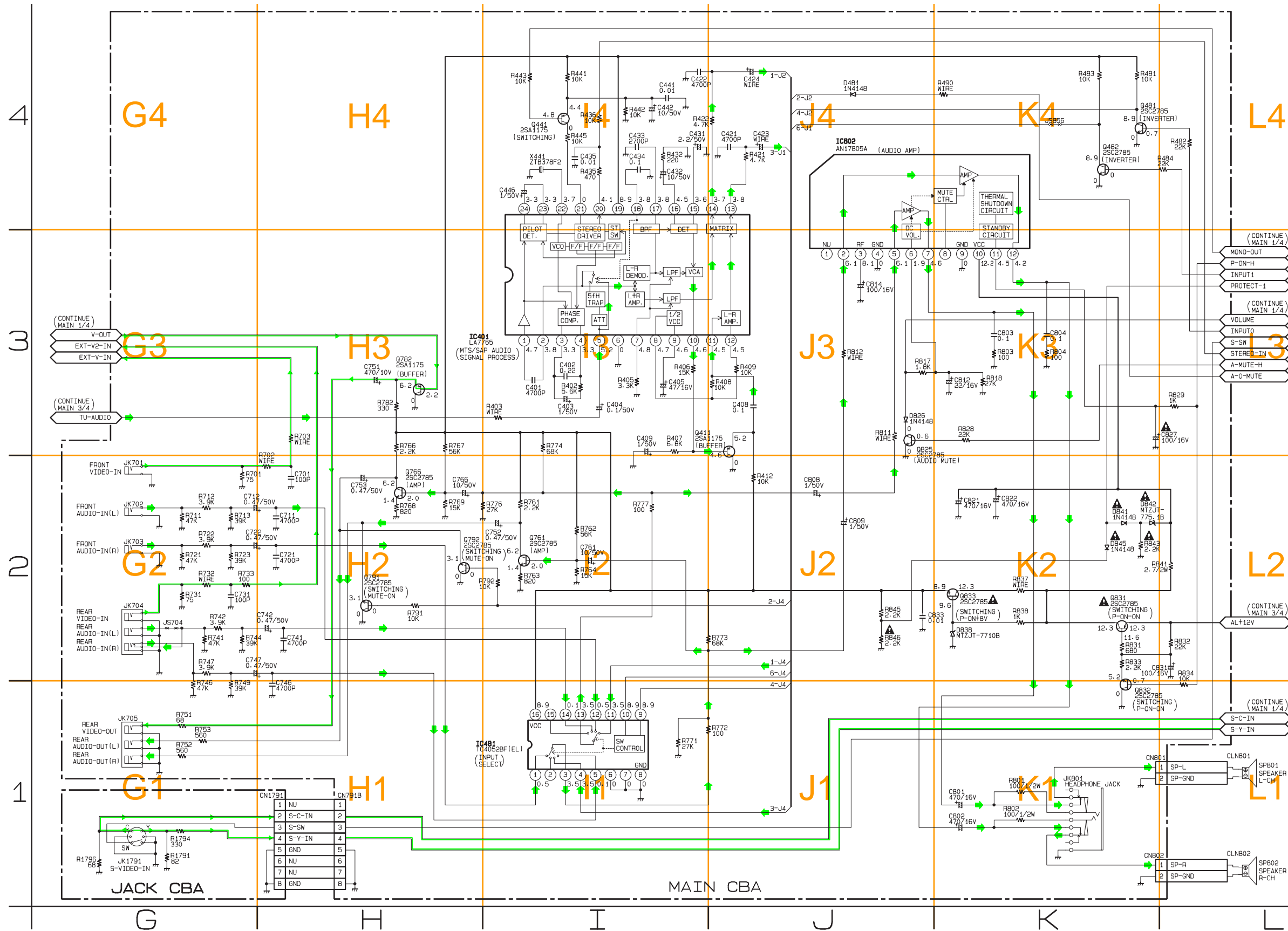

MAIN 2/4

Ref No.	Position
ICS	
IC401	H-3
IC481	I-1
IC802	J-4
TRANSISTORS	
Q411	I-3
Q441	I-4
Q481	K-4
Q482	K-4
Q761	I-2
Q766	H-2
Q782	H-3
Q791	H-2
Q792	H-2
Q825	J-3
Q831	K-2
Q832	K-1
Q833	K-2
CONNECTORS	
CN791B	H-1
CN801	K-1
CN802	K-1

Main 3/4 Schematic Diagram

- - - - - IF SIGNAL
- VIDEO SIGNAL
- ← AUDIO SIGNAL

CAUTION !

Fixed voltage (or Auto voltage selectable) power supply circuit is used in this unit.
If Main Fuse (F601) is blown, check to see that all components in the power supply circuit are not defective before you connect the AC plug to the AC power supply.
Otherwise it may cause some components in the power supply circuit to fail.

NOTE :

The voltage for parts in hot circuit is measured using hot GND as a common terminal.



CAUTION: FOR CONTINUED PROTECTION AGAINST RISK OF FIRE, REPLACE ONLY WITH SAME TYPE 4A, 125V FUSE.
ATTENTION: UTILISER UN FUSIBLE DE RECHANGE DE MÊME TYPE DE 4A, 125V.

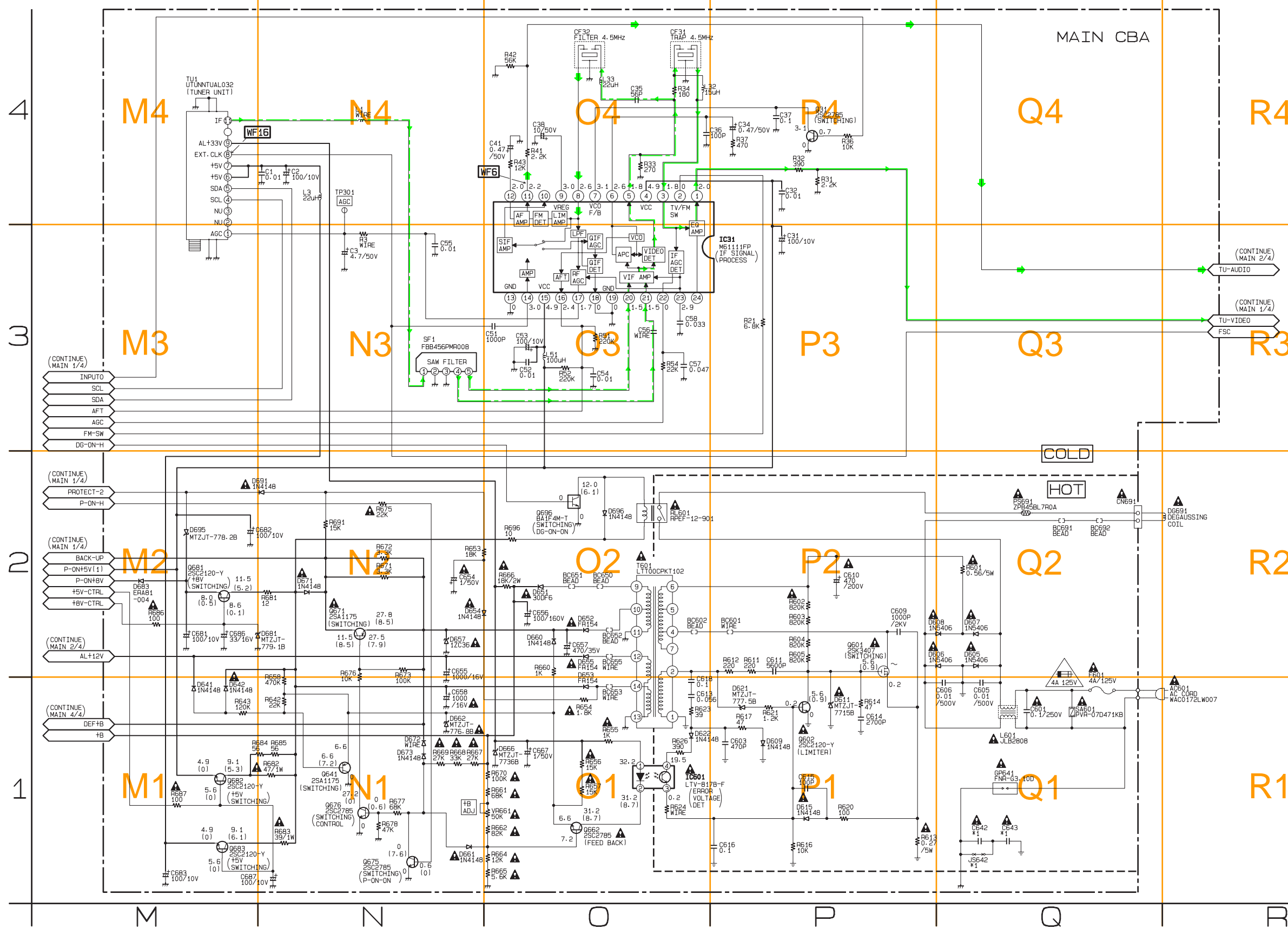

MAIN 3/4	
Ref No.	Position
ICS	
IC31	P-3
IC601	O-1
TRANSISTORS	
Q31	P-4
Q601	P-2
Q602	P-1
Q641	N-1
Q662	O-1
Q671	N-2
Q675	N-1
Q676	N-1
Q681	M-1
Q682	M-1
Q683	M-1
Q696	O-2
CONNECTOR	
CN691	Q-2
TEST POINT	
TP301	N-4
VARIABLE RESISTOR	
VR661	O-1

Main 4/4 & CRT Schematic Diagram

MAIN 4/4

Ref No.	Position	Ref No.	Position	Ref No.	Position
IC		TRANSISTORS		TEST POINTS	
IC551	S-3	Q572	T-2	TP592	U-2
TRANSISTORS		CONNECTORS		VARIABLE RESISTORS	
Q531	S-2	CN571	T-3	VR561	U-3
Q532	S-2	WH301A	V-2	VR562	U-3
Q551	T-3	WH501A	V-3		
Q552	T-3	TEST POINTS			
Q553	U-2	TP300	U-2		
Q561	U-3	TP302	V-2		
Q571	U-2	TP591	U-2		

CRT

Ref No.	Position
TRANSISTORS	
Q1512	W-2
Q1522	W-2
Q1532	W-2
CONNECTORS	
CN1501	X-2
WH301B	V-2
WH501B	V-3
TEST POINTS	
TP1501	X-2
TP1502	W-3

VIDEO SIGNAL

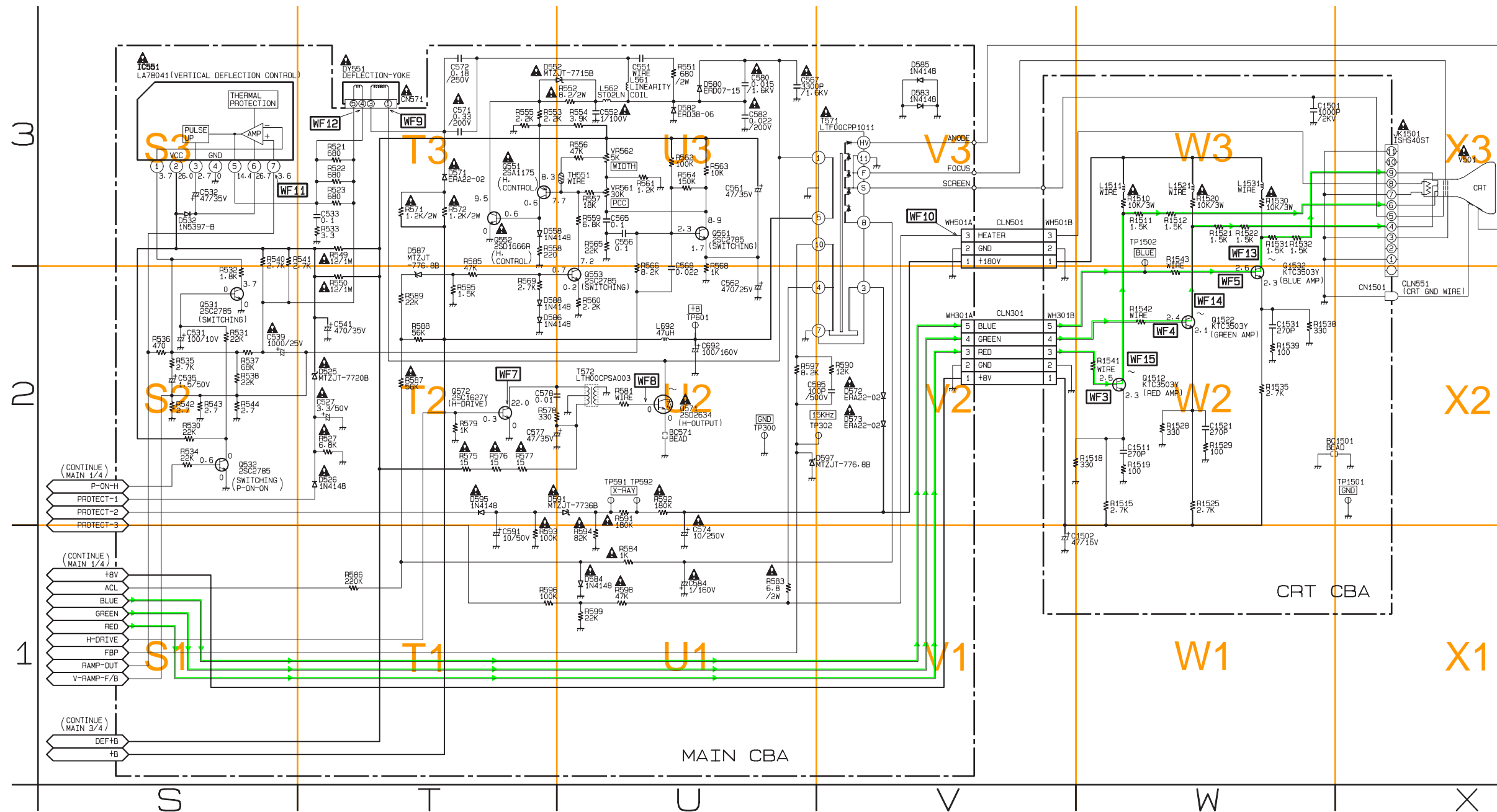

Main CBA Top View

CAUTION !

Fixed voltage (or Auto voltage selectable) power supply circuit is used in this unit.
 If Main Fuse (F601) is blown, check to see that all components in the power supply circuit are not defective before you connect the AC plug to the AC power supply.
 Otherwise it may cause some components in the power supply circuit to fail.



CAUTION: FOR CONTINUED PROTECTION AGAINST RISK OF FIRE, REPLACE ONLY WITH SAME TYPE 4A, 125V FUSE.
ATTENTION: UTILISER UN FUSIBLE DE REMPLACEMENT DE MÊME TYPE DE 4A, 125V.

NOTE :

The voltage for parts in hot circuit is measured using hot GND as a common terminal.

BECAUSE A HOT CHASSIS GROUND IS PRESENT IN THE POWER SUPPLY CIRCUIT, AN ISOLATION TRANSFORMER MUST BE USED. ALSO, IN ORDER TO HAVE THE ABILITY TO INCREASE THE INPUT SLOWLY, WHEN TROUBLESHOOTING THIS TYPE POWER SUPPLY CIRCUIT, A VARIABLE ISOLATION TRANSFORMER IS REQUIRED.

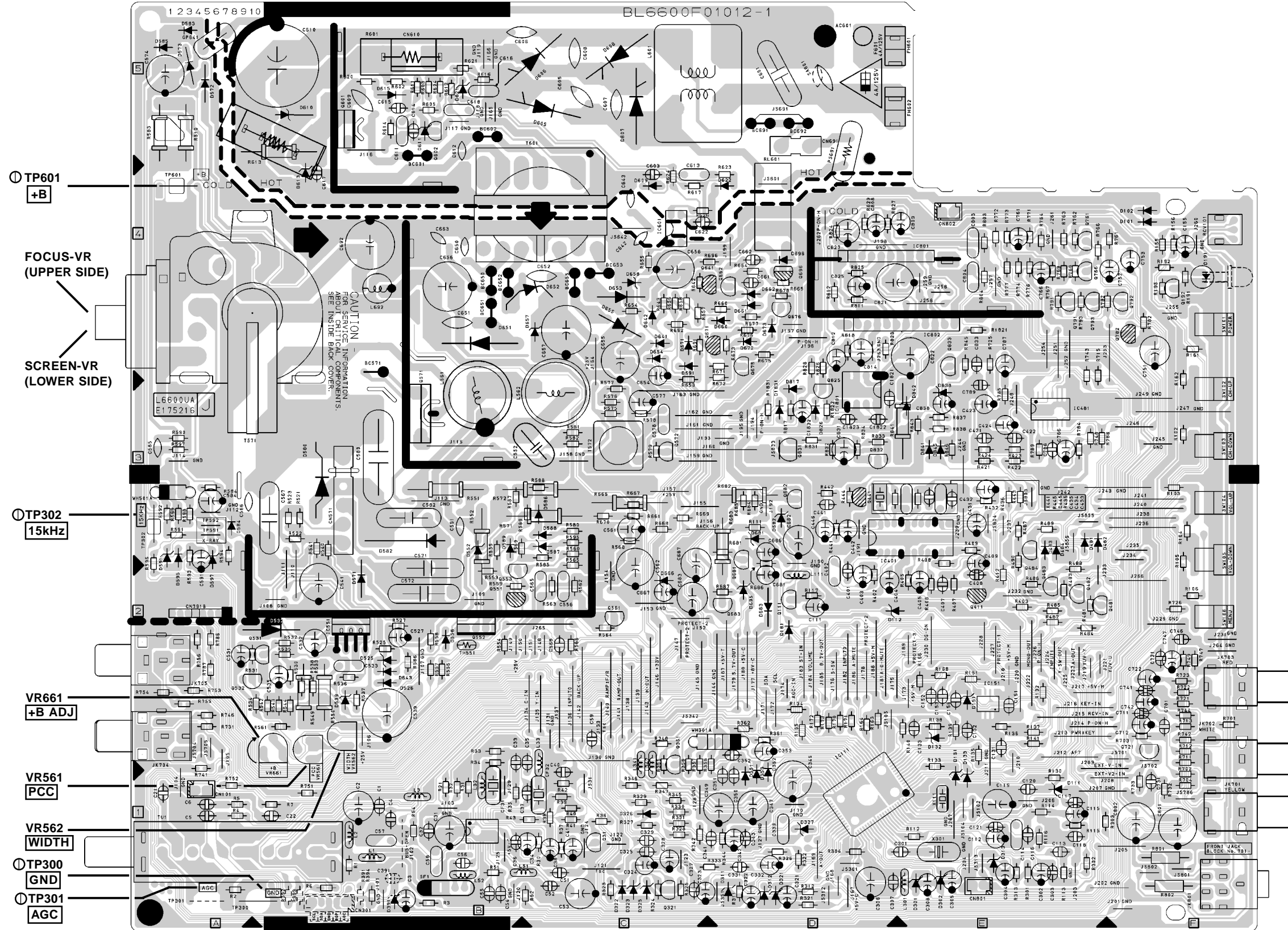

MAIN CBA		
Ref No.	Position	
ICS		
IC31	B-1	
IC111	D-2	
IC151	E-2	
IC401	D-3	
IC481	E-3	
IC551	B-2	
IC601	C-4	
IC802	E-4	
TRANSISTORS		
Q31	C-1	
Q111	D-2	
Q321	C-1	
Q411	E-2	
Q441	D-3	
Q481	F-2	
Q482	E-2	
Q531	B-2	
Q532	A-2	
Q551	B-2	
Q552	B-2	
Q553	B-2	
Q561	C-2	
Q571	B-4	
Q572	C-3	
Q601	B-5	
Q602	B-5	
Q641	D-4	
Q662	D-4	
Q671	D-4	
Q675	D-4	
Q676	D-4	
Q681	D-2	
Q682	D-3	
Q683	D-2	
Q696	D-4	
Q761	E-4	
Q766	E-4	
Q782	F-4	
Q791	E-4	
Q792	F-4	
Q825	D-4	
Q831	D-3	
Q832	D-3	
Q833	E-4	
CONNECTORS		
CN571	B-3	
CN691	D-5	
CN801	E-1	
CN802	E-4	
WH301A	C-2	
WH501A	A-3	
CN791B	A-2	
TEST POINTS		
TP300	A-1	
TP301	A-1	
TP302	A-3	
TP591	A-3	
TP592	A-3	
TP601	A-4	
VARIABLE RESISTOR		
VR561	B-2	
VR562	B-2	
VR661	B-2	

Main CBA Bottom View

CAUTION !

Fixed voltage (or Auto voltage selectable) power supply circuit is used in this unit.
 If Main Fuse (F601) is blown, check to see that all components in the power supply circuit are not defective before you connect the AC plug to the AC power supply.
 Otherwise it may cause some components in the power supply circuit to fail.



CAUTION: FOR CONTINUED PROTECTION AGAINST RISK OF FIRE, REPLACE ONLY WITH SAME TYPE 4A, 125V FUSE.
ATTENTION: UTILISER UN FUSIBLE DE RECHANGE DE MÊME TYPE DE 4A, 125V.
NOTE :
 The voltage for parts in hot circuit is measured using hot GND as a common terminal.

BECAUSE A HOT CHASSIS GROUND IS PRESENT IN THE POWER SUPPLY CIRCUIT, AN ISOLATION TRANSFORMER MUST BE USED. ALSO, IN ORDER TO HAVE THE ABILITY TO INCREASE THE INPUT SLOWLY, WHEN TROUBLESHOOTING THIS TYPE POWER SUPPLY CIRCUIT, A VARIABLE ISOLATION TRANSFORMER IS REQUIRED.

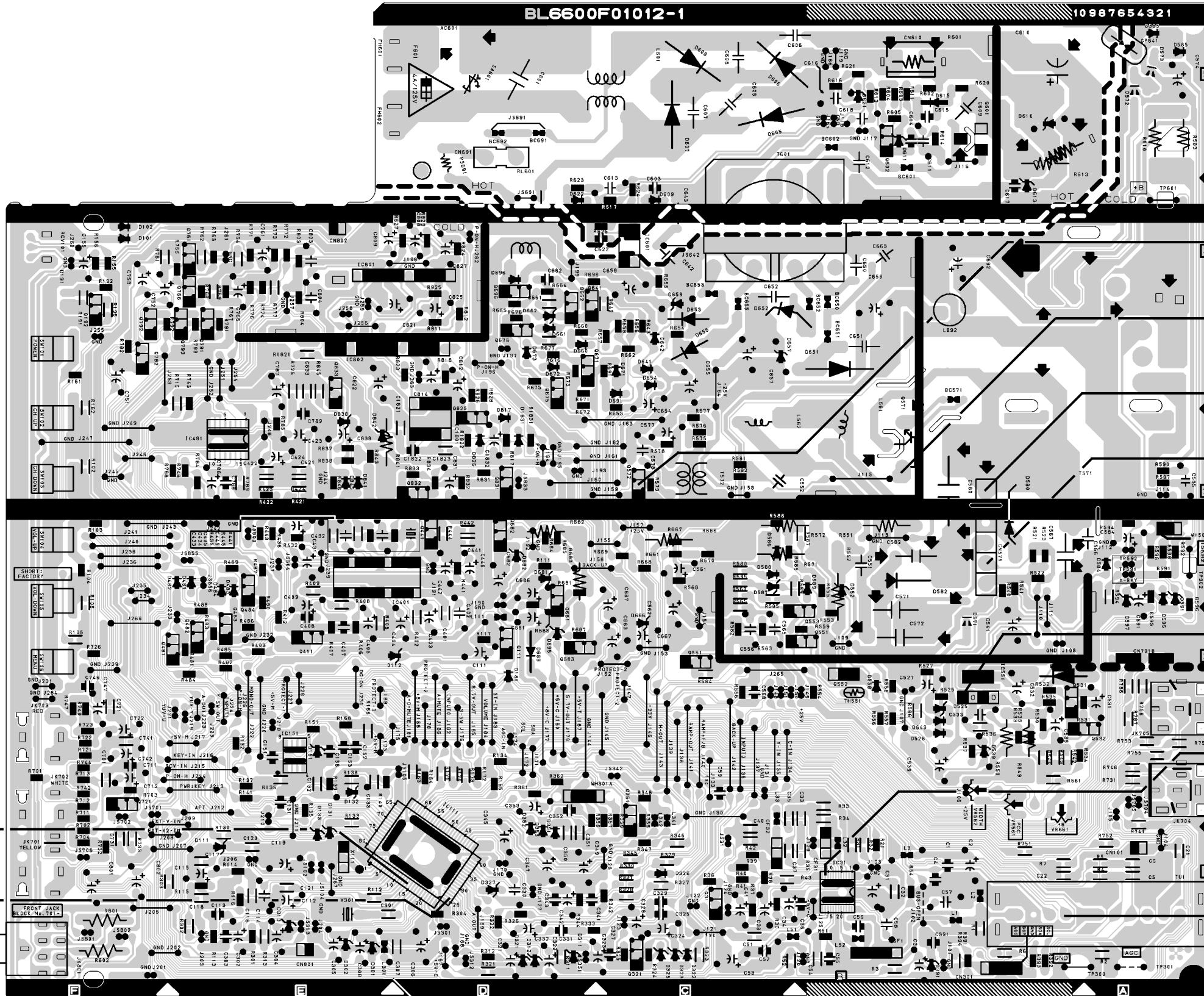

- WF2**
PIN 14
OF IC111
- WF1**
PIN 26
OF IC111

- WF7**
Q572
Collector
- WF8**
Q571
Base
- WF9**
PIN 1
OF CN571
- WF12**
PIN 4
OF CN571
- WF10**
PIN 3
OF WH501A
- WF11**
PIN 7
OF IC551
- WF6**
PIN 11
OF IC31
- WF16**
PIN 8
OF TU1

CRT CBA Top View

CRT CBA Bottom View

CRT CBA

Ref No.	Position
TRANSISTORS	
Q1512	B-1
Q1522	B-1
Q1532	A-1
CONNECTORS	
CN1501	A-2
WH301B	B-1
WH501B	A-1
TEST POINTS	
TP1501	A-2
TP1502	B-1

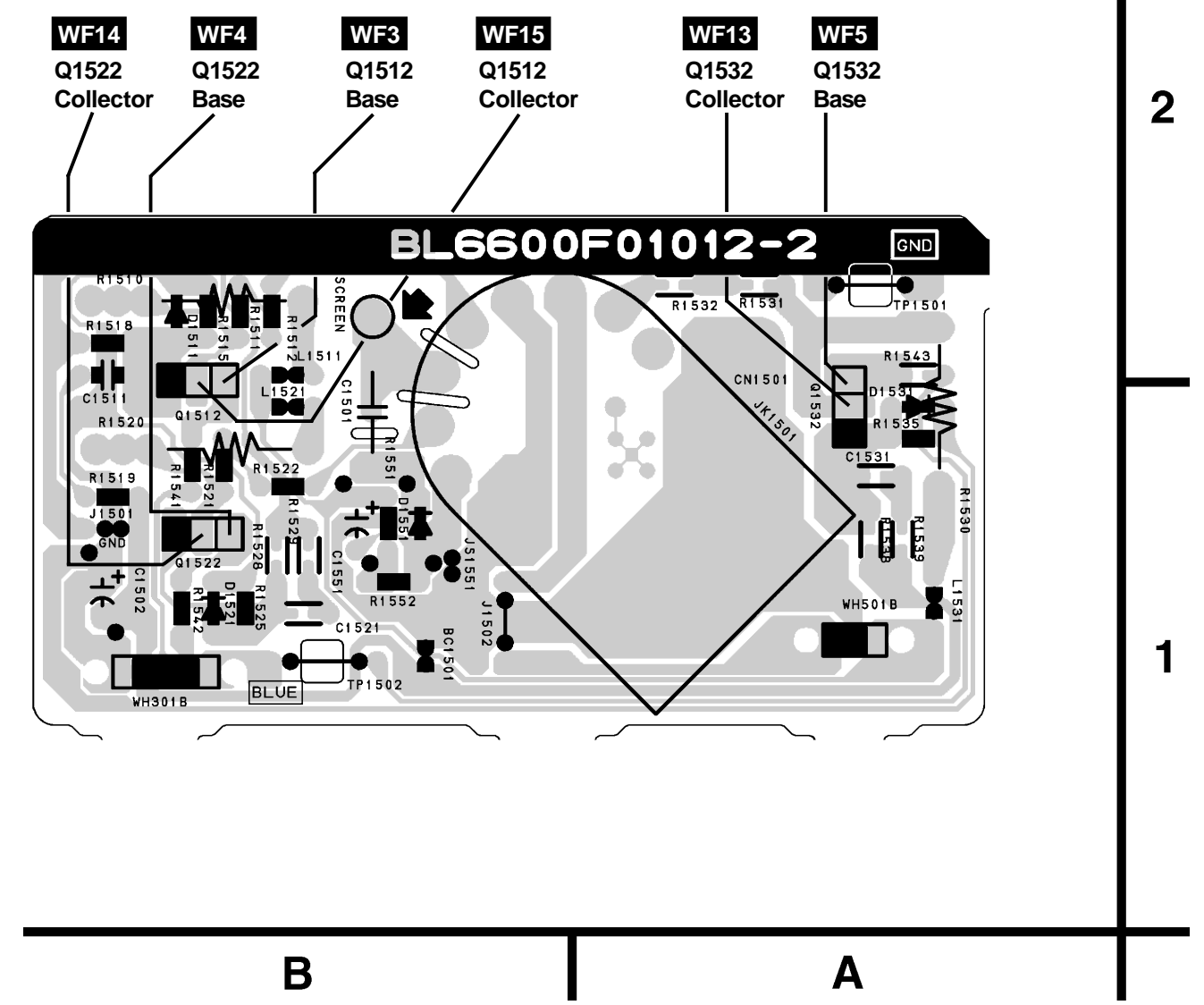
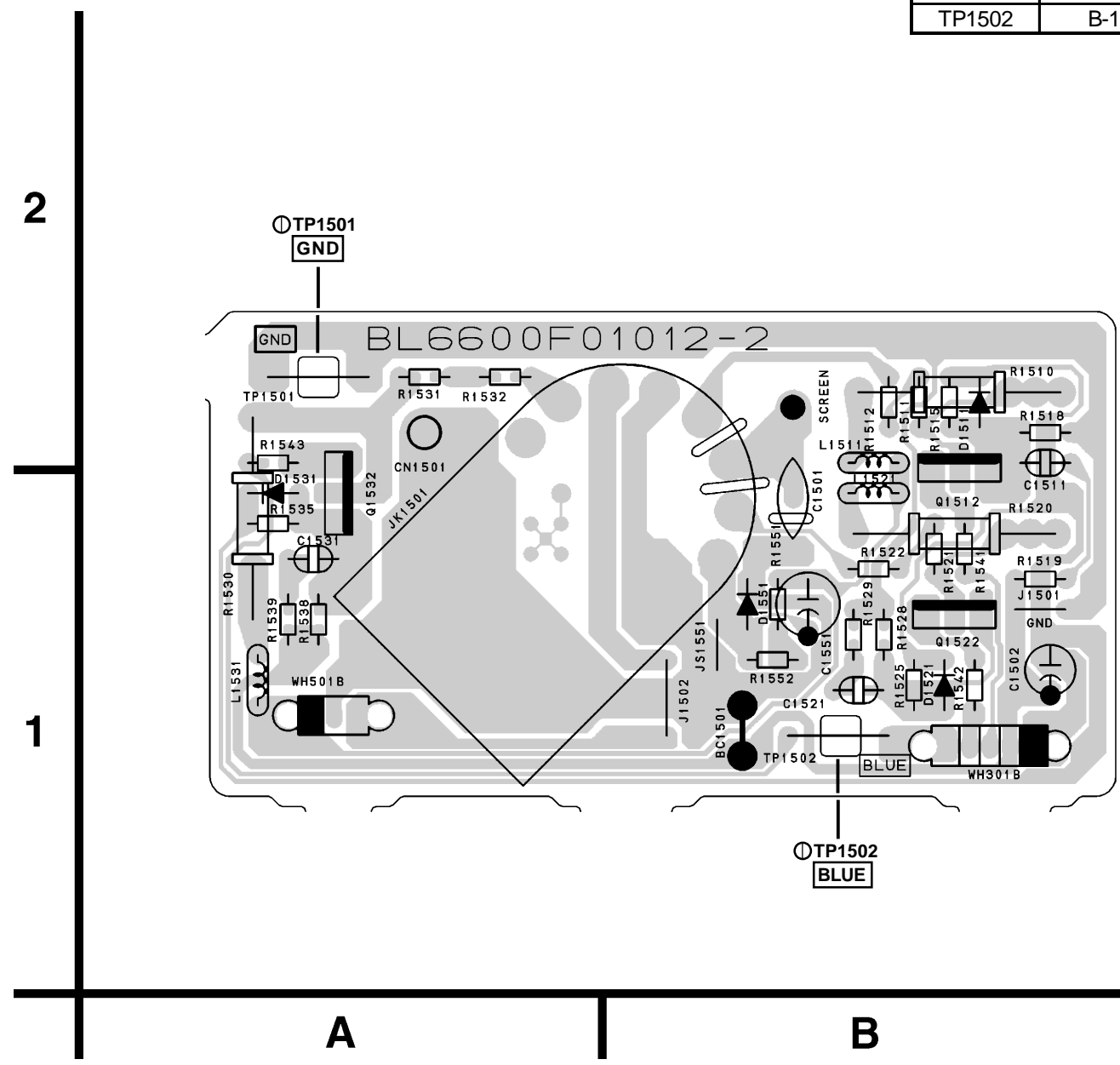

Jack CBA Top View

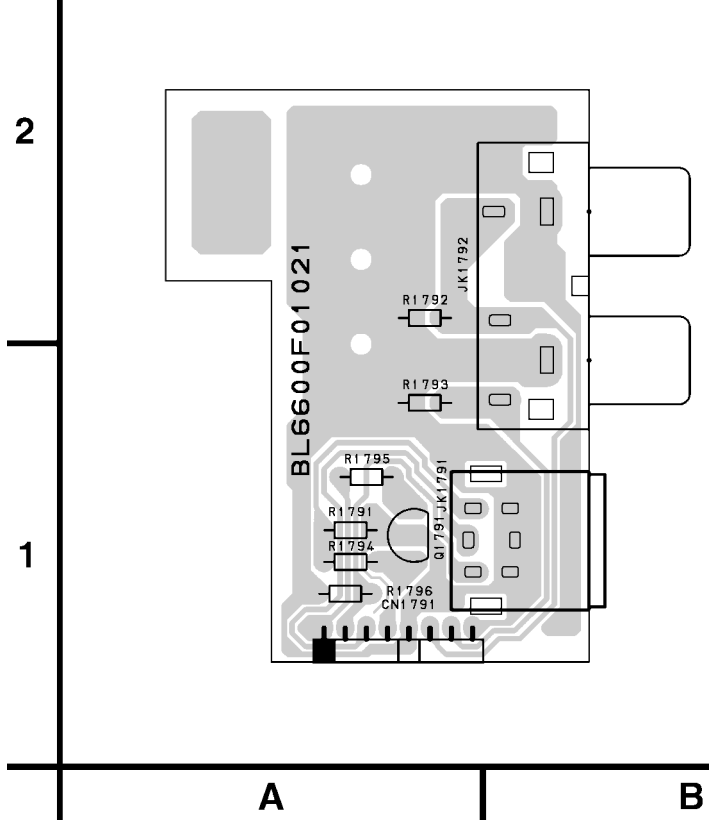

Jack CBA Bottom View

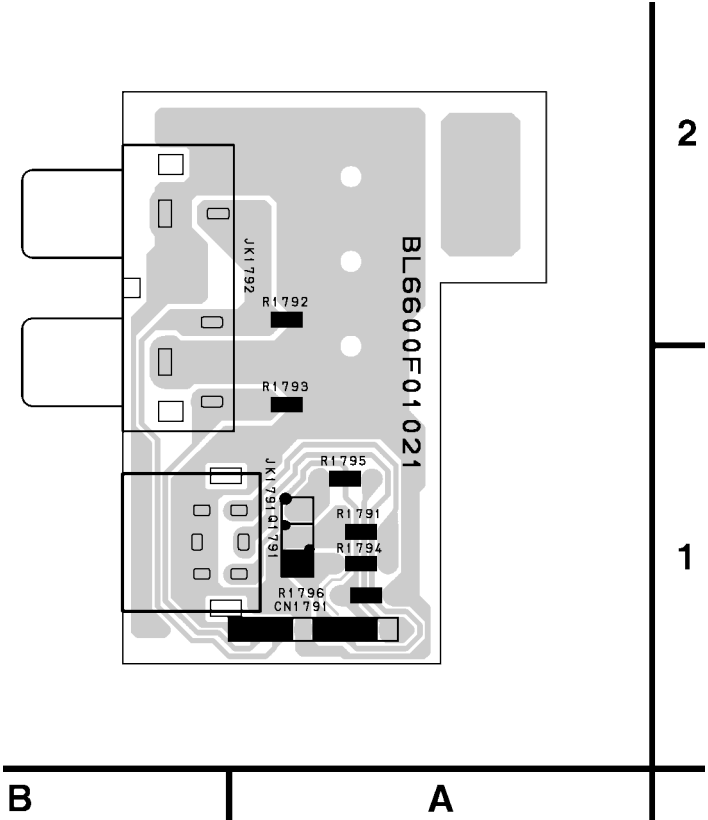

WAVEFORMS

WF1 ~ WF16 = Waveforms to be observed at Waveform check points. (Shown in Schematic Diagram.)

Input: NTSC Color Bar Signal (with 1kHz Audio Signal)
INITIAL POSITION: Unplug unit from AC outlet for at least 5 minutes. reconnect to AC outlet and then turn power on.
 (Brightness---Center Color---Center Tint --- Center Contrast---Approx 70%)

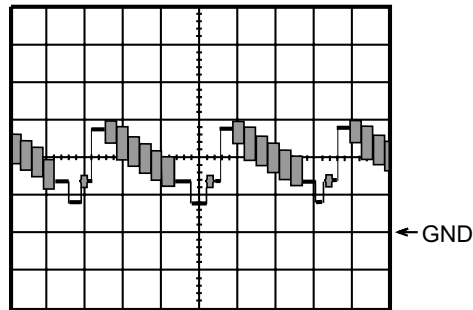

WF1 1DIV: 0.5V 20μsec
IC 111 Pin 26

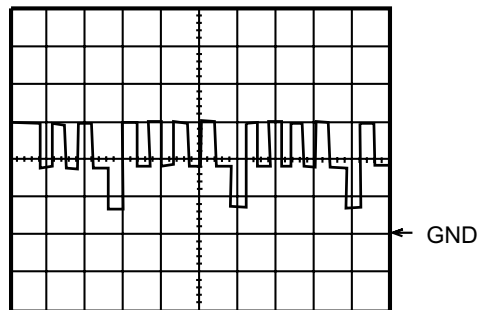

WF5 1DIV: 2V 20μsec
Q 1532 Base

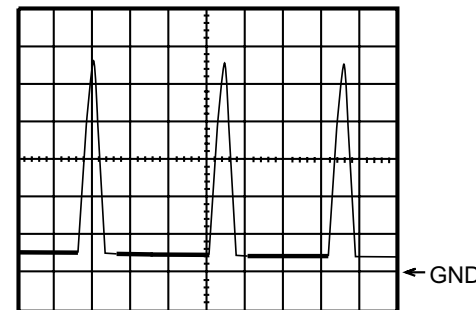

WF9 1DIV: 200V 20μsec
CN 571 Pin 1

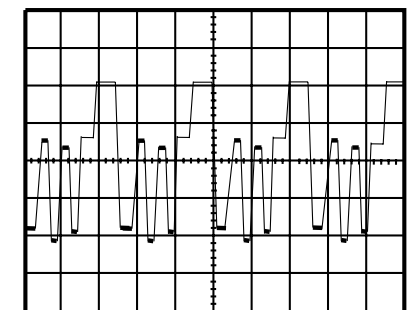

WF13 1DIV: 20V 20μsec
Q1532 Collector

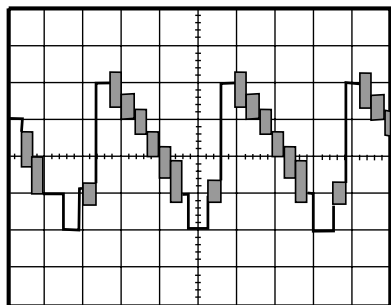

WF2 1DIV: 0.5V 20μsec
IC 111 Pin 14

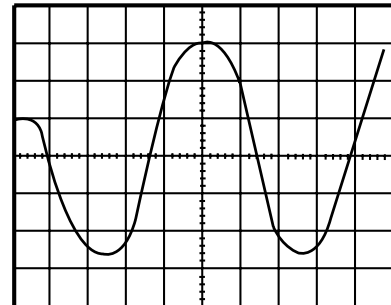

WF6 1DIV: 0.2V 20msec
IC 31 Pin 11

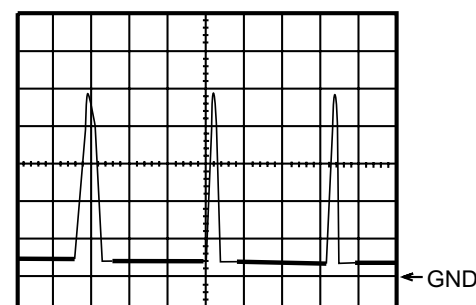

WF10 1DIV: 5V 20μsec
WH501A Pin 3

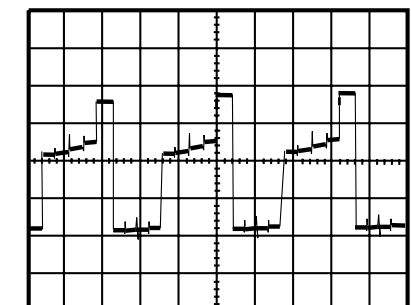

WF14 1DIV: 20V 20μsec
Q 1522 Collector

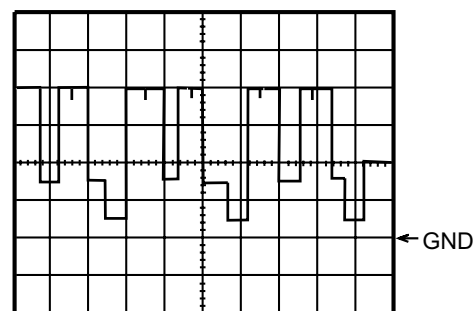

WF3 1DIV: 2V 20μsec
Q1512 Base

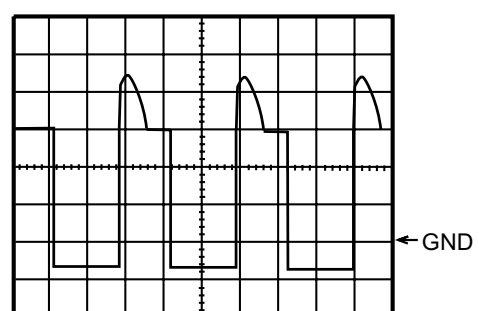

WF7 1DIV: 10V 20μsec
Q 572 Collector

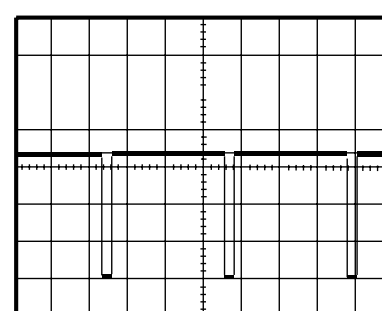

WF11 1DIV: 2V 5msec
IC 551 Pin 7

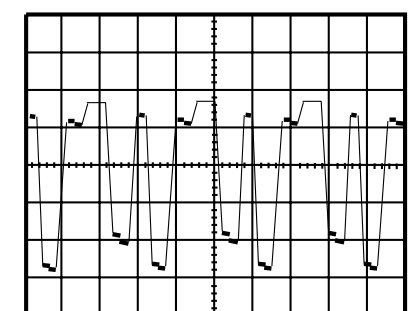

WF15 1DIV: 20V 20μsec
Q 1512 Collector

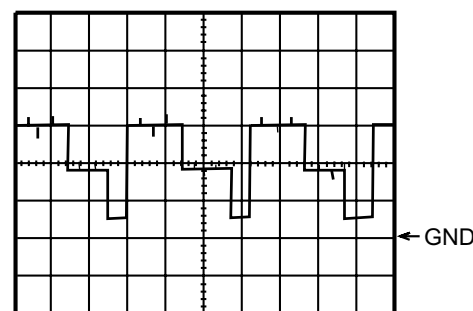

WF4 1DIV: 2V 20μsec
Q 1522 Base

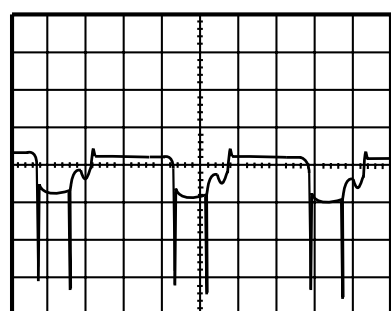

WF8 1DIV: 5V 20μsec
Q 571 Base

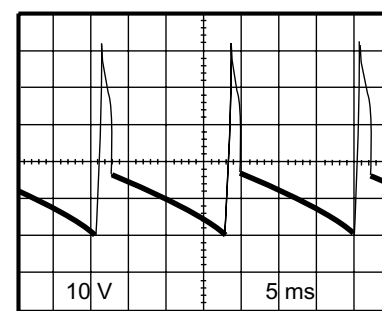

WF12 1DIV: 10V 5msec
CN 571 Pin 4

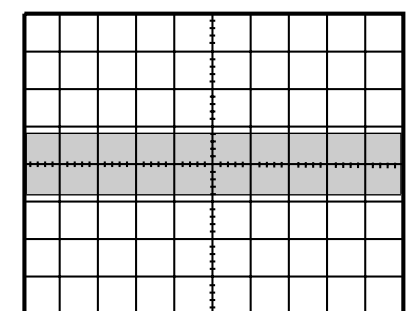

WF16 1DIV: 0.2V 20μsec
TU 1 Pin 8

WIRING DIAGRAM

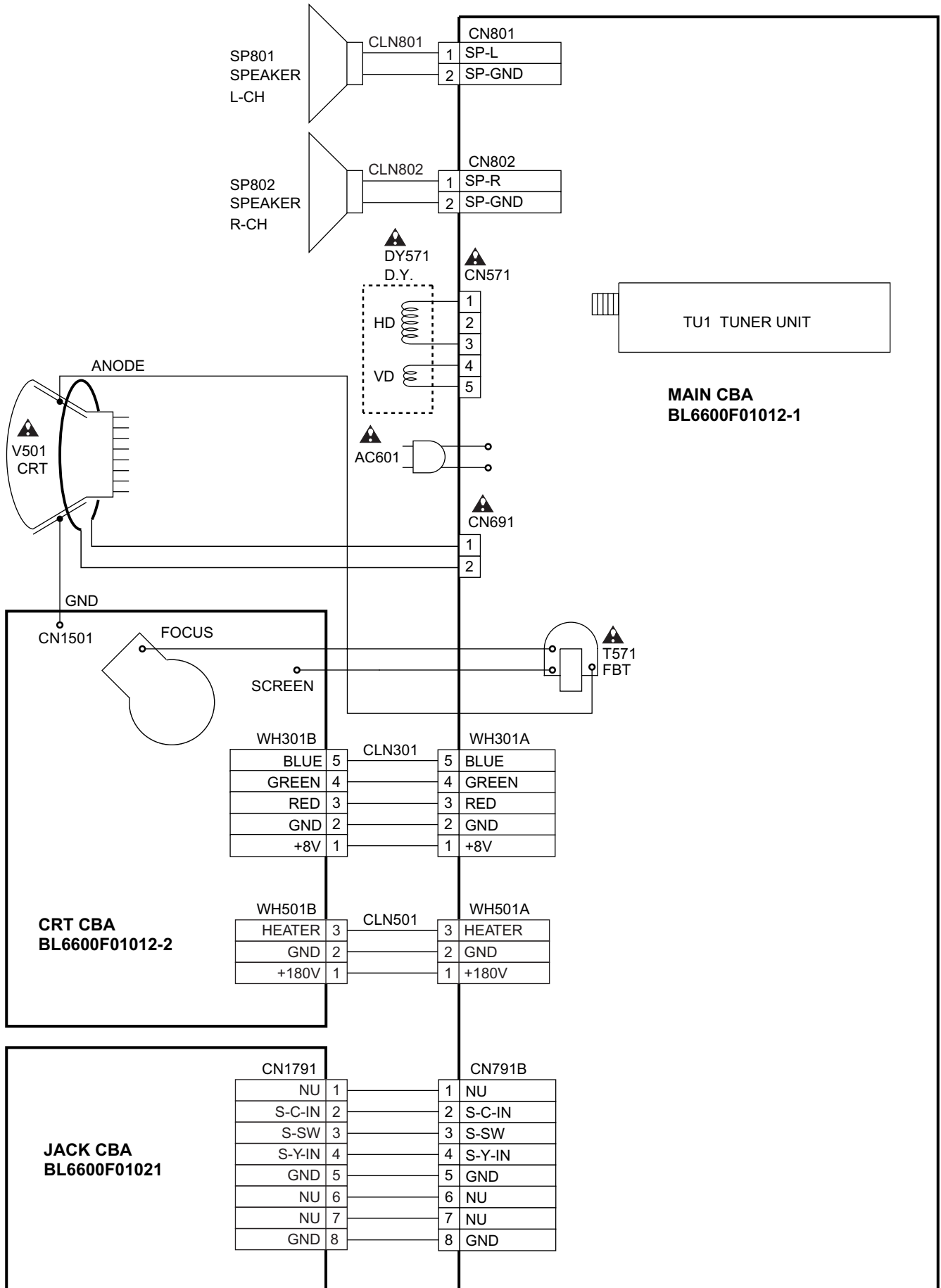

IC PIN FUNCTIONS

IC111(TV Micro Computer)

Pin No.	Signal Name	Function
1	GND	GND
2	N.U.	Not Used
3	N.U.	Not Used
4	N.U.	Not Used
5	GND	GND
6	VCC	AL+5V
7	N.U.	Not Used
8	FILT	FILT
9	HLF	Filter for CCD
10	VHOLD	VHOLD
11	CVIN	Input for Video Signal
12	RESET	RESET
13	MCU RESET OUT	RESET Signal Output
14	Y-SW OUT	Composite Signal Output
15	GND	GND
16	3.58 X'TAL	3.58MHz Crystal
17	C-APC	CHROMINANCE APC
18	MCU 5.7REG OUT	Micro controller Control Voltage Output
19	N.U.	Not Used
20	N.U.	Not Used
21	N.U.	Not Used
22	VCC	VCC
23	N.U.	(GND)
24	CVBS IN2	Composite Signal Input 2
25	N.U.	Not Used
26	CVBS IN1	Composite Signal Input 1
27	N.U.	Not Used
28	5.7V REG OUT	5.7V Output
29	N.U.	Not Used
30	N.U.	Not Used
31	V REG VCC	DC 8.7V Input
32	FSC OUT	Clock Output 3.58MHz
33	N.U.	Not Used
34	N.U.	Not Used

Pin No.	Signal Name	Function
35	N.U.	Not Used
36	N.U.	Not Used
37	V RAMP F/B	V Ramp Feed Back
38	V RAMP OUT	Vertical Output
39	V RAMP CAP	V Ramp OSC Capacitor
40	8.7 VREG OUT	DC 8.7V Output
41	N.U.	Not Used
42	H VCO F/B	H Vco Feed Back
43	AFC FILT	Horizontal AFC Filter
44	GND	GND
45	FBP IN	Flyback Pulse Input
46	H-OUT	H Pulse Output
47	VCC	Vcc
48	VCC	Vcc
49	VCC	Vcc
50	R OUT	Red Output
51	G OUT	Green Output
52	B OUT	Blue Output
53	ACL	IB-Input
54	N.U.	Not Used
55	N.U.	Not Used
56	SDA	I2C-BUS Controller Interface (Data)
57	N.U.	Not Used
58	SCL	I2C-BUS Controller Interface (Clock)
59	N.U.	(GND)
60	STEREO-IN	STEREO-IN
61	N.U.	Not Used
62	VOLUME	Volume
63	INPUTO	EXT-H
64	A-MUTE-H	Audio Mute
65	N.U.	Not Used
66	KEY-IN 1	Key Input 1 (Main)
67	PROTECT-2	Power Supply Protection
68	PROTECT-1	Power Supply Protection
69	KEY-IN 2	Key Input 2 (Main)
70	RCV-IN	Input For Remote Control

Pin No.	Signal Name	Function
71	MONO-OUT	MONO-OUT
72	I2C OPEN	White Balance Adjustment Judgement
73	AFT	AFT Voltage Input
74	DG-ON-H	Degaussing Coil Control
75	AGC	AGC Voltage Input
76	PROTECT 3	Power Supply Protection
77	N.U.	Not Used
78	FM-SW	Switching IF IC VCO
79	P-ON-H	Output for P-ON-H
80	N.U.	Not Used

EXPLODED VIEWS

Cabinet

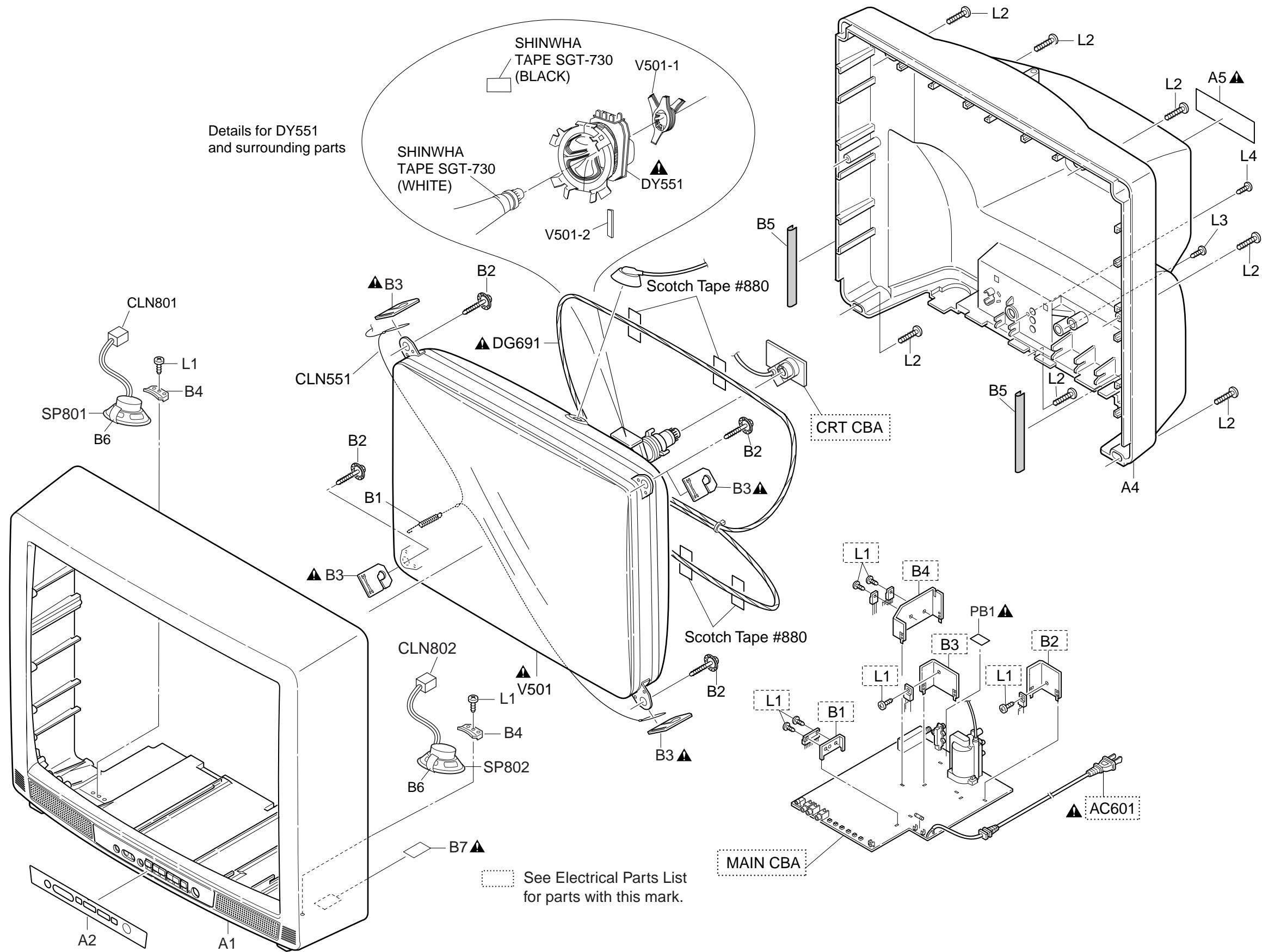

Packing

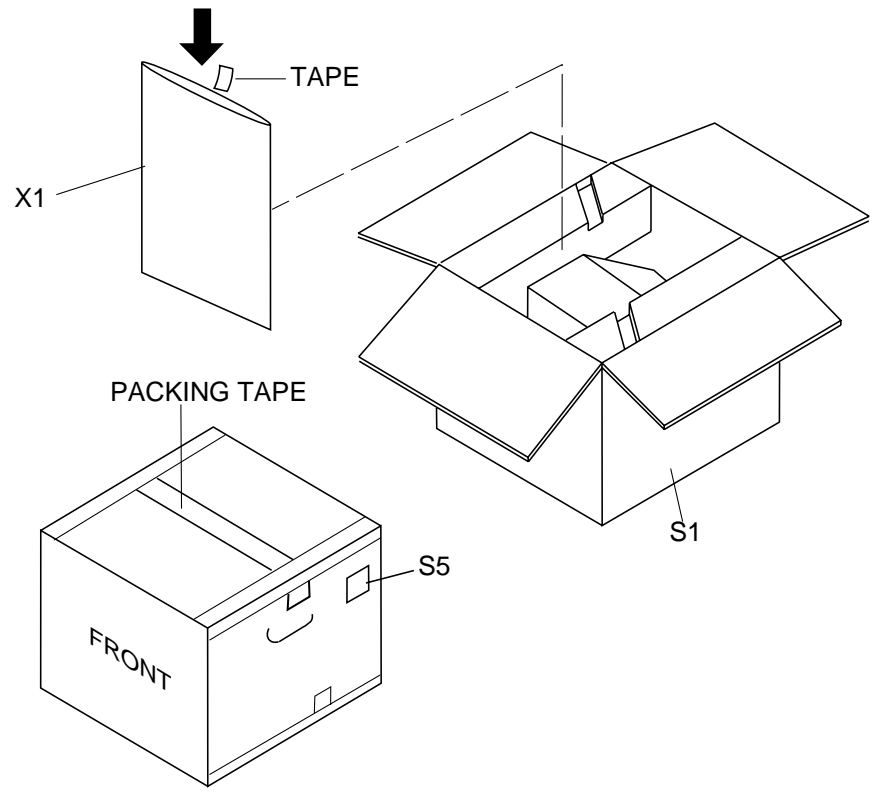
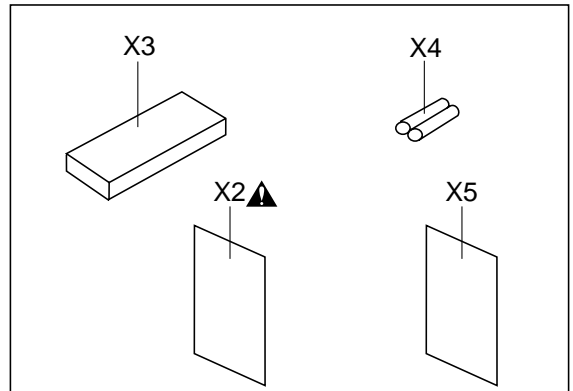
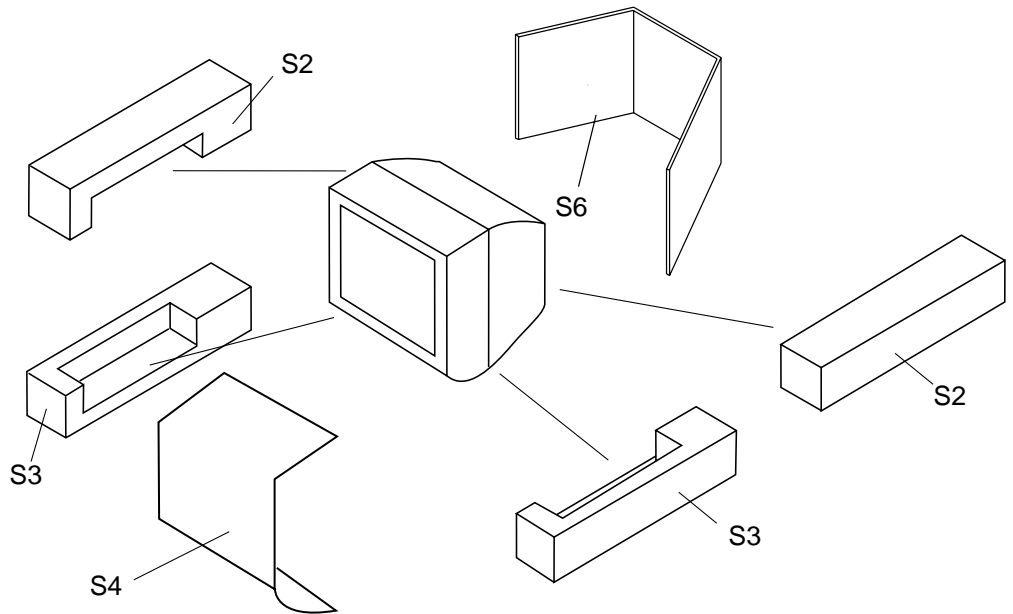

Ref No.	Description	Parts No.
	C6427TD(L6603CD)	20030221
	MECHANICAL PARTS LIST	
A1	FRONT CABINET L6201UB	0EM000648
A2	CONTROL PLATE L6602UC	0EM301903
A4	REAR CABINET L6603CD	0EM101291
A5!	RATING LABEL L6603CD	-----
B1	TENSION SPRING B0080B0:EM40808	26WH006
B2	M7 CRT SCREW(D22) T7205UF	0EM406573
B3!	DEGAUSS HOLDER L1200UA	0EM405869
B4	SPEAKER HOLDER L1200UA	0EM405691
B5	CLOTH L9800UA:95X15XT:0.5	0EM405041
B6	CLOTH(10X30XT1.0) L9814UQ	0EM405137
B7!	CRITICAL PARTS WARNING LABEL B8007C3:EM41210	-----
CLN551	CRT GND WIRE CRT GND	WX1L1200-007
CLN801	WIRE ASSEMBLY SPEAKER WIRE(180MM)	WX1L9800-001
CLN802	WIRE ASSEMBLY SPEAKER WIRE(180MM)	WX1L1131-001
DG691!	DEGAUSSING COIL F-029	LLBH00ZTM029
DG691!	DEGAUSSING COIL AVDG156	LLBH00ZWR043
L1	SCREW, P-TIGHT 3X12 BIND HEAD+	GBMP3120
L2	SCREW, P-TIGHT 4X18 BIND HEAD +	GBMP4180
L3	SCREW TAPPING M4X14	DBU14140
L4	SCREW, P-TIGHT 3X10 BIND HEAD+	GBKP3100
SP801	SPEAKER S08N04	DSD0808XQ013
SP802	SPEAKER S08N04	DSD0808XQ013
PB1!	CHASSIS NO. LABEL L6603CD	-----
S1	CARTON L6603CD	0EM407829
S2	STYROFOAM TOP ASSEMBLY L6201UB	0EM407225
S3	STYROFOAM BOTTOM ASSEMBLY L6201UB	0EM407226
S4	SET SHEET PCEC:003502019816	0EM403887
S5	SERIAL NO. LABEL L6603CD	-----
S6	HOLD PAD L6201UB	0EM407287
X1	POLYETHYLENE BAG F8626B5	Z325350
X2!	OWNER'S MANUAL L6603CD:ENGLISH/SPANISH	0EMN02079
X3	REMOTE CONTROL 130/ERC001/N0160UD	N0160UD
X4	DRY BATTERY R6P UM3	XB0M451GH001
X4	DRY BATTERY R6P/2S	XB0M451T0001
X4	DRY BATTERY(SUNRISE) R6SSE/2S	XB0M451MS002
X4	DRY BATTERY R6P(AR)2PX	XB0M451HU002
X4	DRY BATTERY R6P(AR)2P X ICI	XB0M451HU003
X7!	QUICK SETUP GUIDE L1004CE	0EMN01726
	CRT TYPE A	
DY551!	DEFLECTION YOKE ODY-C29029	LLBY00ZQS006
V501!	CRT A68KTB359X(B)	TCRT190QS024
V501!	CRT A68KTB359X(PB)	TCRT190QS025
V501!	CRT A68KTB259X2	TCRT190QS021
V501!	CRT A68KTB259X(P)	TCRT190QS023
V501-1	PCM JH88DTA	XM04000BV010
V501-2	WEDGE FT-00110W	XV10000T4001
V501-2	WEDGE DB25SR	XV10000D9001
	CRT TYPE B	
DY551!	DEFLECTION YOKE CDY-F2927H	LLBY00ZQS014
V501!	CRT A68QBT892X	TCRT190SM028
V501-1	PCM JH88DTA	XM04000BV010
V501-2	WEDGE FT-00110W	XV10000T4001
V501-2	WEDGE DB25SR	XV10000D9001

	CRT TYPE C	
DY551!	DEFLECTION YOKE 6150Z-1046A	LLBY00ZGS008
DY551!	DEFLECTION YOKE KDY4UWE21X	LLBY00ZMS026
V501!	CRT A68QBC230X	TCRT190GS043
V501-1	PCM JH88DTA	XM04000BV010
V501-2	WEDGE FT-00110W	XV10000T4001
V501-2	WEDGE DB25SR	XV10000D9001
	ELECTRICAL PARTS LIST	
	MMA-402 CBA	0ESA05145
	Consists of the following	
	MAIN CBA	-----
	CRT CBA	-----
	MAIN CBA	-----
AC601!	AC CORD LA-2413	WAC0172LW007
B1	HEAT SINK(PHI) L6600UZ	0EM407654
B2	HEAT SINK(PHH)ASSEMBLY L6600UZ	0EM407653
B3	HEAT SINK(PHF)ASSEMBLY L6600UZ	0EM407649
B4	HEAT SINK(PHG)ASSEMBLY L6600UZ	0EM407651
BC571	BEAD INDUCTORS FBA04HA600VB-00	LLBF00STU026
BC601	PCB JUMPER D0.6-P5.0	JW5.0T
BC602	BEAD INDUCTORS FBR07HA121TB-00	LLBF00ZTU021
BC650	BEAD INDUCTORS FBR07HA121TB-00	LLBF00ZTU021
BC651	BEAD INDUCTORS FBR07HA121TB-00	LLBF00ZTU021
BC652	BEAD INDUCTORS FBR07HA121TB-00	LLBF00ZTU021
BC653	PCB JUMPER D0.6-P5.0	JW5.0T
BC655	PCB JUMPER D0.6-P5.0	JW5.0T
BC691	BEAD INDUCTORS FBR07HA121TB-00	LLBF00ZTU021
BC692	BEAD INDUCTORS FBR07HA121TB-00	LLBF00ZTU021
C1	CERAMIC CAP.(AX) F Z 0.01UF/25V	CDA1EZT0F103
C2	ELECTROLYTIC CAP. 100UF/10V M	CE1AMASTL101
C2	ELECTROLYTIC CAP. 100UF/10V M	CE1AMASDL101
C3	ELECTROLYTIC CAP. 4.7UF/50V M	CE1JMASTL4R7
C3	ELECTROLYTIC CAP. 4.7UF/50V M	CE1JMASDL4R7
C31	ELECTROLYTIC CAP. 100UF/10V M	CE1AMASTL101
C31	ELECTROLYTIC CAP. 100UF/10V M	CE1AMASDL101
C32	CERAMIC CAP.(AX) F Z 0.01UF/25V	CDA1EZT0F103
C34	ELECTROLYTIC CAP. 0.47UF/50V M	CE1JMASTLR47
C34	ELECTROLYTIC CAP. 0.47UF/50V M	CE1JMASDLR47
C35	CERAMIC CAP.(AX) CH J 56PF/50V	CA1J560TU008
C36	CERAMIC CAP.(AX) B K 100PF/50V	CCA1JKT0B101
C37	CERAMIC CAP.(AX) F Z 0.1UF/50V	CA1J104TU014
C37	CERAMIC CAP.(AX) F Z 0.1UF/50V	CCA1J2T0F104
C38	ELECTROLYTIC CAP. 10UF/50V M	CE1JMASTL100
C38	ELECTROLYTIC CAP. 10UF/50V M	CE1JMASDL100
C41	ELECTROLYTIC CAP. 0.47UF/50V M	CE1JMASTLR47
C41	ELECTROLYTIC CAP. 0.47UF/50V M	CE1JMASDLR47
C51	CERAMIC CAP.(AX) B K 1000PF/50V	CCA1JKT0B102
C52	CERAMIC CAP.(AX) F Z 0.01UF/25V	CDA1EZT0F103
C53	ELECTROLYTIC CAP. 100UF/10V M	CE1AMASTL101
C53	ELECTROLYTIC CAP. 100UF/10V M	CE1AMASDL101
C54	CERAMIC CAP.(AX) B K 0.01UF/50V	CA1J103TU011
C55	CERAMIC CAP.(AX) F Z 0.01UF/25V	CDA1EZT0F103
C56	PCB JUMPER D0.6-P5.0	JW5.0T
C57	FILM CAP.(P) 0.047UF/50V J	CMA1JJS00473
C57	FILM CAP.(P) 0.047UF/50V J	CA1J473MS029
C58	FILM CAP.(P) 0.033UF/50V J	CMA1JJS00333

C58	FILM CAP.(P) 0.033UF/50V J	CA1J333MS029
C111	ELECTROLYTIC CAP. 47UF/16V M	CE1CMASSTL470
C111	ELECTROLYTIC CAP. 47UF/16V M	CE1CMASDL470
C112	ELECTROLYTIC CAP. 4.7UF/50V M	CE1JMASTL4R7
C112	ELECTROLYTIC CAP. 4.7UF/50V M	CE1JMASDL4R7
C113	CERAMIC CAP.(AX) F Z 0.1UF/50V	CA1J104TU014
C113	CERAMIC CAP.(AX) F Z 0.1UF/50V	CCA1JZT0F104
C114	FILM CAP.(P) 0.001UF/50V J	CMA1JJS00102
C114	FILM CAP.(P) 0.001UF/50V J	CA1J102MS029
C115	ELECTROLYTIC CAP. 0.1UF/50V M	CE1JMASTLR10
C115	ELECTROLYTIC CAP. 0.1UF/50V M	CE1JMASDLR10
C115	ELECTROLYTIC CAP. 0.1UF/50V M	CE1JMASDLR01
C116	CERAMIC CAP.(AX) B K 220PF/50V	CCA1JKT0B221
C117	CERAMIC CAP.(AX) Y K 0.01UF/16V	CDA1CKT0Y103
C119	ELECTROLYTIC CAP. 100UF/10V M	CE1AMASTL101
C119	ELECTROLYTIC CAP. 100UF/10V M	CE1AMASDL101
C120	CERAMIC CAP.(AX) F Z 0.01UF/25V	CDA1EZT0F103
C121	CERAMIC CAP.(AX) B K 470PF/50V	CCA1JKT0B471
C132	CERAMIC CAP.(AX) F Z 0.1UF/50V	CA1J104TU014
C132	CERAMIC CAP.(AX) F Z 0.1UF/50V	CCA1JZT0F104
C133	CERAMIC CAP.(AX) F Z 0.01UF/25V	CDA1EZT0F103
C151	CERAMIC CAP.(AX) F Z 0.01UF/25V	CDA1EZT0F103
C152	CERAMIC CAP.(AX) B K 220PF/50V	CCA1JKT0B221
C153	CERAMIC CAP.(AX) B K 220PF/50V	CCA1JKT0B221
C155	ELECTROLYTIC CAP. 47UF/16V M	CE1CMASSTL470
C155	ELECTROLYTIC CAP. 47UF/16V M	CE1CMASDL470
C156	CERAMIC CAP.(AX) F Z 0.1UF/50V	CA1J104TU014
C156	CERAMIC CAP.(AX) F Z 0.1UF/50V	CCA1JZT0F104
C301	CERAMIC CAP.(AX) CH J 120PF/50V	CA1J121TU008
C302	ELECTROLYTIC CAP. 1UF/50V M	CE1JMASTL1R0
C302	ELECTROLYTIC CAP. 1UF/50V M	CE1JMASDL1R0
C302	ELECTROLYTIC CAP. 1UF/50V M	CE1JMASDL010
C303	CERAMIC CAP.(AX) B K 0.015UF/50V	CA1J153TU011
C305	ELECTROLYTIC CAP. 0.47UF/50V M	CE1JMASTLR47
C305	ELECTROLYTIC CAP. 0.47UF/50V M	CE1JMASDLR47
C306	ELECTROLYTIC CAP. 100UF/10V M	CE1AMASTL101
C306	ELECTROLYTIC CAP. 100UF/10V M	CE1AMASDL101
C308	ELECTROLYTIC CAP. 0.47UF/50V M	CE1JMASTLR47
C308	ELECTROLYTIC CAP. 0.47UF/50V M	CE1JMADSLR47
C322	ELECTROLYTIC CAP. 0.47UF/50V M	CE1JMASTLR47
C322	ELECTROLYTIC CAP. 0.47UF/50V M	CE1JMADSLR47
C324	ELECTROLYTIC CAP. 10UF/50V M	CE1JMASTL100
C324	ELECTROLYTIC CAP. 10UF/50V M	CE1JMASDL100
C325	CERAMIC CAP.(AX) B K 220PF/50V	CCA1JKT0B221
C328	ELECTROLYTIC CAP. 10UF/50V M	CE1JMASTL100
C328	ELECTROLYTIC CAP. 10UF/50V M	CE1JMADSL100
C329	CERAMIC CAP.(AX) F Z 0.01UF/25V	CDA1EZT0F103
C330	STACKED FILM CAP. 0.47UF/50V J	CMA1JJS00474
C331	CERAMIC CAP.(AX) B K 1000PF/50V	CCA1JKT0B102
C332	ELECTROLYTIC CAP. 10UF/50V M	CE1JMASTL100
C332	ELECTROLYTIC CAP. 10UF/50V M	CE1JMADSL100
C341	CERAMIC CAP.(AX) B K 0.01UF/50V	CA1J103TU011
C342	ELECTROLYTIC CAP. 1UF/50V M	CE1JMASTL1R0
C342	ELECTROLYTIC CAP. 1UF/50V M	CE1JMADSL1R0
C342	ELECTROLYTIC CAP. 1UF/50V M	CE1JMADSL010
C343	CERAMIC CAP.(AX) B K 0.01UF/50V	CA1J103TU011
C345	ELECTROLYTIC CAP. 2200UF/10V M	CE1AMZNTL222
C345	ELECTROLYTIC CAP. 2200UF/10V M	CE1AMZNDL222

C347	ELECTROLYTIC CAP. 470UF/10V M	CE1AMASTL471
C347	ELECTROLYTIC CAP. 470UF/10V M	CE1AMASDL471
C349	ELECTROLYTIC CAP. 470UF/10V M	CE1AMASTL471
C349	ELECTROLYTIC CAP. 470UF/10V M	CE1AMASDL471
C353	ELECTROLYTIC CAP. 1UF/50V M	CE1JMASTL1R0
C353	ELECTROLYTIC CAP. 1UF/50V M	CE1JMASDL1R0
C353	ELECTROLYTIC CAP. 1UF/50V M	CE1JMADSL010
C401	CERAMIC CAP.(AX) X K 4700PF/16V	CDA1CKT0X472
C402	MYLAR CAP. 0.22UF/50V J	CMA1JJS00224
C402	FILM CAP.(P) 0.22UF/50V J	CA1J224MS029
C403	ELECTROLYTIC CAP. 1UF/50V M	CE1JMASTL1R0
C403	ELECTROLYTIC CAP. 1UF/50V M	CE1JMADSL1R0
C403	ELECTROLYTIC CAP. 1UF/50V M	CE1JMADSL010
C404	ELECTROLYTIC CAP. 0.1UF/50V M	CE1JMASTLR10
C404	ELECTROLYTIC CAP. 0.1UF/50V M	CE1JMADSLR10
C404	ELECTROLYTIC CAP. 0.1UF/50V M	CE1JMADSL010
C404	ELECTROLYTIC CAP. 0.1UF/50V M	CE1JMADSLR01
C405	ELECTROLYTIC CAP. 47UF/16V M	CE1CMASSTL470
C405	ELECTROLYTIC CAP. 47UF/16V M	CE1CMASDL470
C408	CERAMIC CAP.(AX) F Z 0.1UF/50V	CA1J104TU014
C408	CERAMIC CAP.(AX) F Z 0.1UF/50V	CCA1JZT0F104
C409	ELECTROLYTIC CAP. 1UF/50V M	CE1JMASTL1R0
C409	ELECTROLYTIC CAP. 1UF/50V M	CE1JMADSL1R0
C409	ELECTROLYTIC CAP. 1UF/50V M	CE1JMADSL010
C421	CERAMIC CAP.(AX) X K 4700PF/16V	CDA1CKT0X472
C422	CERAMIC CAP.(AX) X K 4700PF/16V	CDA1CKT0X472
C423	PCB JUMPER D0.6-P5.0	JW5.0T
C424	PCB JUMPER D0.6-P5.0	JW5.0T
C431	ELECTROLYTIC CAP. 2.2UF/50V M	CE1JMASTL2R2
C431	ELECTROLYTIC CAP. 2.2UF/50V M	CE1JMADSL2R2
C432	ELECTROLYTIC CAP. 10UF/50V M	CE1JMASTL100
C432	ELECTROLYTIC CAP. 10UF/50V M	CE1JMADSL100
C433	CERAMIC CAP.(AX) X K 2700PF/16V	CDA1CKT0X272
C434	FILM CAP.(P) 0.1UF/50V J	CMA1JJS00104
C434	FILM CAP.(P) 0.1UF/50V J	CA1J104MS029
C435	CERAMIC CAP.(AX) F Z 0.01UF/25V	CDA1EZT0F103
C441	CERAMIC CAP.(AX) F Z 0.01UF/25V	CDA1EZT0F103
C442	ELECTROLYTIC CAP. 10UF/50V M	CE1JMASTL100
C442	ELECTROLYTIC CAP. 10UF/50V M	CE1JMADSL100
C446	ELECTROLYTIC CAP. 1UF/50V M	CE1JMASTL1R0
C446	ELECTROLYTIC CAP. 1UF/50V M	CE1JMADSL1R0
C446	ELECTROLYTIC CAP. 1UF/50V M	CE1JMADSL010
C527	ELECTROLYTIC CAP. 3.3UF/50V M	CE1JMASTL3R3
C527	ELECTROLYTIC CAP. 3.3UF/50V M	CE1JMADSL3R3
C531	ELECTROLYTIC CAP. 100UF/10V M	CE1AMASTL101
C531	ELECTROLYTIC CAP. 100UF/10V M	CE1AMASDL101
C532	ELECTROLYTIC CAP. 47UF/35V M	CE1GMASSTL470
C532	ELECTROLYTIC CAP. 47UF/35V M	CE1GMASDL470
C533	FILM CAP.(P) 0.1UF/50V J	CMA1JJS00104
C533	FILM CAP.(P) 0.1UF/50V J	CA1J104MS029
C535	ELECTROLYTIC CAP. 1.5UF/50V M LL	CE1JMASLL1R5
C539!	ELECTROLYTIC CAP. 1000UF/25V M	CE1EMZNTL102
C539!	ELECTROLYTIC CAP. 1000UF/25V M	CE1EMZPDL102
C539!	ELECTROLYTIC CAP. 1000UF/25V M	CE1EMZADL102
C541	ELECTROLYTIC CAP. 470UF/35V M(VR)	CE1GMZNTL471
C541	ELECTROLYTIC CAP. 470UF/35V M	CE1GMZADL471
C541	ELECTROLYTIC CAP. 470UF/35V M	CE1GMZNDL471
C551	PCB JUMPER D0.6-P5.0	JW5.0T
C552!	METALIZED PLYESTER CAP. 1UF/100V J	CT2A105MS065

C556	FILM CAP.(P) 0.1UF/50V J	CMA1JJS00104
C556	FILM CAP.(P) 0.1UF/50V J	CA1J104MS029
C561	ELECTROLYTIC CAP. 47UF/35V M	CE1GMASSTL470
C561	ELECTROLYTIC CAP. 47UF/35V M	CE1GMASDL470
C562	ELECTROLYTIC CAP. 470UF/25V M	CE1EMZNTL471
C562	ELECTROLYTIC CAP. 470UF/25V M	CE1EMZNDL471
C562	ELECTROLYTIC CAP. 470UF/25V M	CE1EMZADL471
C565	FILM CAP.(P) 0.1UF/50V J	CMA1JJS00104
C565	FILM CAP.(P) 0.1UF/50V J	CA1J104MS029
C567!	PP CAP. 0.0033UF/1.6KV J	CA3C332VC010
C567!	PP CAP. 0.0033UF/1.6KV J	CT3C332MS039
C567!	PP CAP. 0.0033UF/1.6KV J	CBH3CJQ00332
C567!	METALLIZED FILM CAP. 0.0033UF/1.6KV J	CT3C332F7002
C568	CERAMIC CAP.(AX) B K 0.022UF/50V	CA1J223TU011
C571	P.P. CAP 0.33UF/200V J	CA2D334VC012
C571	PP CAP. 0.33UF/250V J	CT2E334MS041
C571	METALLIZED FILM CAP. 0.33UF/200V J	CT2D334F7001
C572	P.P. CAP 0.18UF/200V J	CA2D184VC012
C572	PP CAP. 0.18UF/250V J	CT2E184MS041
C572	METALLIZED FILM CAP. 0.18UF/200V J	CT2D184F7001
C574!	ELECTROLYTIC CAP. 10UF/250V M	CE2EMASDL100
C577	ELECTROLYTIC CAP. 47UF/35V M	CE1GMASSTL470
C577	ELECTROLYTIC CAP. 47UF/35V M	CE1GMASDL470
C578	FILM CAP.(P) 0.01UF/50V J	CMA1JJS00103
C578	FILM CAP.(P) 0.01UF/50V J	CA1J103MS029
C580!	PP CAP. 0.015UF/1.6KV J	CA3C153VC010
C580!	PP CAP. 0.015UF/1.6KV J	CT3C153MS039
C580!	PP CAP. 0.015UF/1.6KV J	CBH3CJQ00153
C582	P.P. CAP. 0.022UF/200V J	CA2D223VC013
C582	P.P. CAP. 0.022UF/200V K	CBP2DKD00223
C582	METALLIZED FILM CAP. 0.022UF/200V J	CT2D223F7002
C584!	ELECTROLYTIC CAP. 1UF/160V M	CE2CMASSTL1R0
C584!	ELECTROLYTIC CAP. 1UF/160V M	CE2CMASDL1R0
C585	CERAMIC CAP. B K 100PF/500V	CCD2JKS0B101
C591!	ELECTROLYTIC CAP. 10UF/50V M	CE1JMASSTL100
C591!	ELECTROLYTIC CAP. 10UF/50V M	CE1JMASDL100
C601!	METALLIZED FILM CAP. 0.1UF/250V	CT2E104MS037
C601!	FILM CAP.(MP) 0.1UF/250V K	CT2E104DC011
C601!	METALLIZED FILM CAP. 0.1UF/275V K	CT2E104HJE06
C603	CERAMIC CAP.(AX) B K 470PF/50V	CCA1JKT0B471
C605!	CERAMIC CAP. F Z 0.01UF/500V	CCD2JZP0F103
C605!	CERAMIC CAP. 0.01UF/AC250V	CCD2EZA0F103
C606!	CERAMIC CAP. F Z 0.01UF/500V	CCD2JZP0F103
C606!	CERAMIC CAP. 0.01UF/AC250V	CCD2EZA0F103
C609	CERAMIC CAP. B K 1000PF/2KV	CCD3DKD0B102
C609	CERAMIC CAP. B K 1000PF/2KV	CCD3DKP0B102
C609	CERAMIC CAP. 1000PF/2KV	CA3D102PAN04
C610!	ELECTROLYTIC CAP. 470UF/200V	CA2D471NC013
C610!	ELECTROLYTIC CAP. 470UF/200V M	CE2DMZNDL471
C611	FILM CAP.(P) 0.0056UF/50V J	CMA1JJS00562
C611	FILM CAP.(P) 0.0056UF/50V J	CA1J562MS029
C613	FILM CAP.(P) 0.056UF/50V J	CMA1JJS00563
C613	FILM CAP.(P) 0.056UF/50V J	CA1J563MS029
C614	CERAMIC CAP.(AX) X K 2700PF/16V	CDA1CKT0X472
C615	CERAMIC CAP.(AX) B K 100PF/50V	CCA1JKT0B101
C616	FILM CAP.(P) 0.1UF/50V J	CMA1JJS00104
C616	FILM CAP.(P) 0.1UF/50V J	CA1J104MS029
C618	FILM CAP.(P) 0.1UF/50V J	CMA1JJS00104

C618	FILM CAP.(P) 0.1UF/50V J	CA1J104MS029
If C642 is 0.01UF, then C643 is 0.01UF.		
C642!	SAFETY CAP. 10000PF/250V	CCG2EMA0F103
C642!	SAFETY CAP. F M 0.01UF/250V	CCG2EMPOF103
C642!	CERAMIC CAP. 0.01UF F CS	CCG2HMNOF103
C643!	SAFETY CAP. 10000PF/250V	CCG2EMA0F103
C643!	SAFETY CAP. F M 0.01UF/250V	CCG2EMPOF103
C643!	CERAMIC CAP. 0.01UF F CS	CCG2HMNOF103
If C643 is 4700PF, then JS642 (PCBJUMPER) is used.		
C643!	SAFETY CAP. 4700PF/250V KX	
JS642	PCB JUMPER D0.6-P10.0	JW10.0T
C654	ELECTROLYTIC CAP. 1UF/50V M	CE1JMASSTL1R0
C654	ELECTROLYTIC CAP. 1UF/50V M	CE1JMASDL1R0
C654	ELECTROLYTIC CAP. 1UF/50V M	CE1JMASDL010
C655!	ELECTROLYTIC CAP. 1000UF/16V M(VR/HC)	CE1CMZNTL102
C655!	ELECTROLYTIC CAP. 1000UF/16V M	CE1CMZPDL102
C655!	ELECTROLYTIC CAP. 1000UF/16V M	CE1CMZADL102
C656	ELECTROLYTIC CAP. 100UF/160V M	CE2CMZPTL101
C656	ELECTROLYTIC CAP. 100UF/160V M	CE2CMZNDL101
C657!	ELECTROLYTIC CAP. 470UF/35V M(VR)	CE1GMZNTL471
C657!	ELECTROLYTIC CAP. 470UF/35V M	CE1GMZADL471
C657!	ELECTROLYTIC CAP. 470UF/35V M	CE1GMZNDL471
C658	ELECTROLYTIC CAP. 1000UF/16V M(VR/HC)	CE1CMZNTL102
C658	ELECTROLYTIC CAP. 1000UF/16V M	CE1CMZPDL102
C658	ELECTROLYTIC CAP. 1000UF/16V M	CE1CMZADL102
C667	ELECTROLYTIC CAP. 1UF/50V M	CE1JMASSTL1R0
C667	ELECTROLYTIC CAP. 1UF/50V M	CE1JMASDL1R0
C667	ELECTROLYTIC CAP. 1UF/50V M	CE1JMASDL010
C681	ELECTROLYTIC CAP. 100UF/10V M	CE1AMASSTL101
C681	ELECTROLYTIC CAP. 100UF/10V M	CE1AMASDL101
C682	ELECTROLYTIC CAP. 100UF/10V M	CE1AMASSTL101
C682	ELECTROLYTIC CAP. 100UF/10V M	CE1AMASDL101
C683	ELECTROLYTIC CAP. 100UF/10V M	CE1AMASSTL101
C683	ELECTROLYTIC CAP. 100UF/10V M	CE1AMASDL101
C686	ELECTROLYTIC CAP. 33UF/16V M	CE1CMASSTL330
C686	ELECTROLYTIC CAP. 33UF/16V M	CE1CMASDL330
C687	ELECTROLYTIC CAP. 100UF/10V M	CE1AMASSTL101
C687	ELECTROLYTIC CAP. 100UF/10V M	CE1AMASDL101
C692	ELECTROLYTIC CAP. 100UF/160V M	CE2CMZPTL101
C692	ELECTROLYTIC CAP. 100UF/160V M	CE2CMZNDL101
C701	CERAMIC CAP.(AX) B K 100PF/50V	CCA1JKT0B101
C711	CERAMIC CAP.(AX) X K 4700PF/16V	CDA1CKT0X472
C712	ELECTROLYTIC CAP. 0.47UF/50V M	CE1JMASSTLR47
C712	ELECTROLYTIC CAP. 0.47UF/50V M	CE1JMASDLR47
C721	CERAMIC CAP.(AX) X K 4700PF/16V	CDA1CKT0X472
C722	ELECTROLYTIC CAP. 0.47UF/50V M	CE1JMASSTLR47
C722	ELECTROLYTIC CAP. 0.47UF/50V M	CE1JMASDLR47
C731	CERAMIC CAP.(AX) B K 100PF/50V	CCA1JKT0B101
C741	CERAMIC CAP.(AX) X K 4700PF/16V	CDA1CKT0X472
C742	ELECTROLYTIC CAP. 0.47UF/50V M	CE1JMASSTLR47
C742	ELECTROLYTIC CAP. 0.47UF/50V M	CE1JMASDLR47
C746	CERAMIC CAP.(AX) X K 4700PF/16V	CDA1CKT0X472
C747	ELECTROLYTIC CAP. 0.47UF/50V M	CE1JMASSTLR47
C747	ELECTROLYTIC CAP. 0.47UF/50V M	CE1JMASDLR47
C751	ELECTROLYTIC CAP. 470UF/10V M	CE1AMASSTL471
C751	ELECTROLYTIC CAP. 470UF/10V M	CE1AMASDL471
C752	ELECTROLYTIC CAP. 0.47UF/50V M	CE1JMASSTLR47
C752	ELECTROLYTIC CAP. 0.47UF/50V M	CE1JMASDLR47

C753	ELECTROLYTIC CAP. 0.47UF/50V M	CE1JMASTLR47
C753	ELECTROLYTIC CAP. 0.47UF/50V M	CE1JMASDLR47
C761	ELECTROLYTIC CAP. 10UF/50V M	CE1JMASTL100
C761	ELECTROLYTIC CAP. 10UF/50V M	CE1JMASDL100
C766	ELECTROLYTIC CAP. 10UF/50V M	CE1JMASTL100
C766	ELECTROLYTIC CAP. 10UF/50V M	CE1JMASDL100
C801	ELECTROLYTIC CAP. 470UF/16V M	CE1CMASTL471
C801	ELECTROLYTIC CAP. 470UF/16V M	CE1CMASDL471
C802	ELECTROLYTIC CAP. 470UF/16V M	CE1CMASTL471
C802	ELECTROLYTIC CAP. 470UF/16V M	CE1CMASDL471
C803	FILM CAP.(P) 0.1UF/50V J	CMA1JJS00104
C803	FILM CAP.(P) 0.1UF/50V J	CA1J104MS029
C804	FILM CAP.(P) 0.1UF/50V J	CMA1JJS00104
C804	FILM CAP.(P) 0.1UF/50V J	CA1J104MS029
C808	ELECTROLYTIC CAP. 1UF/50V M	CE1JMASTL1R0
C808	ELECTROLYTIC CAP. 1UF/50V M	CE1JMASDL1R0
C808	ELECTROLYTIC CAP. 1UF/50V M	CE1JMASDL010
C809	ELECTROLYTIC CAP. 1UF/50V M	CE1JMASTL1R0
C809	ELECTROLYTIC CAP. 1UF/50V M	CE1JMASDL1R0
C809	ELECTROLYTIC CAP. 1UF/50V M	CE1JMASDL010
C812	ELECTROLYTIC CAP. 22UF/16V M	CE1CMASTL220
C812	ELECTROLYTIC CAP. 22UF/16V M	CE1CMASDL220
C814	ELECTROLYTIC CAP. 100UF/16V M	CE1CMASTL101
C814	ELECTROLYTIC CAP. 100UF/16V M	CE1CMASDL101
C821	ELECTROLYTIC CAP. 470UF/16V M	CE1CMASTL471
C821	ELECTROLYTIC CAP. 470UF/16V M	CE1CMASDL471
C822	ELECTROLYTIC CAP. 470UF/16V M	CE1CMASTL471
C822	ELECTROLYTIC CAP. 470UF/16V M	CE1CMASDL471
C827	ELECTROLYTIC CAP. 100UF/16V M	CE1CMASTL101
C827	ELECTROLYTIC CAP. 100UF/16V M	CE1CMASDL101
C831	ELECTROLYTIC CAP. 100UF/16V M	CE1CMASTL101
C831	ELECTROLYTIC CAP. 100UF/16V M	CE1CMASDL101
C833	CERAMIC CAP.(AX) F Z 0.01UF/25V	CDA1EZT0F103
CF31	CERAMIC TRAP 4.5MHZ	FBE455PMR003
CF31	CERAMIC TRAP 4.5MHZ	FBE455PMS002
CF32	CERAMIC FILTER SFSRA4M50CF00-B0	FBB455PMR004
CF32	CERAMIC FILTER 4.5MHZ	FBB455PMS001
CLN301	WIRE ASSEMBLY WX1L1200-102	WX1L1200-102
CLN501	WIRE ASSEMBLY WX1L1200-103	WX1L1200-103
CN571!	CONNECTOR BASE, 5P TV-50P-05-V3	J3TVC05TG002
CN571!	CONNECTOR BASE, 5P RTB-1.5-5P	J3RTC05JG001
CN571!	CONNECTOR BASE, 5P W-P3005-02	1730812
CN691!	CONNECTOR BASE, 2P TV-50P-02-V3	J3TVC02TG002
CN691!	CONNECTOR BASE, 2P RTB-1.5-2P	J3RTC02JG001
CN801	STRAIGHT CONNECTOR BASE 00 8283 0212 00 000	J383C02UG002
CN801	STRAIGHT PIN HEADER, 2P 173981-2	1770258
CN802	STRAIGHT CONNECTOR BASE 00 8283 0212 00 000	J383C02UG002
CN802	STRAIGHT PIN HEADER, 2P 173981-2	1770258
D101	SWITCHING DIODE 1SS133(T-77)	QDTZ001SS133
D101	SWITCHING DIODE 1N4148	NDTZ001N4148
D102	SWITCHING DIODE 1SS133(T-77)	QDTZ001SS133
D102	SWITCHING DIODE 1N4148	NDTZ001N4148
D131	ZENER DIODE MTZJT-775.1B	QDTB0MTZJ5R1
D131	ZENER DIODE DZ-5.1BSBT265	NDTB0DZ5R1BS
D151	ZENER DIODE MTZJT-775.6B	QDTB0MTZJ5R6
D151	ZENER DIODE DZ-5.6BSBT265	NDTB0DZ5R6BS
D181	SWITCHING DIODE 1SS133(T-77)	QDTZ001SS133
D181	SWITCHING DIODE 1N4148	NDTZ001N4148

D322	SWITCHING DIODE 1SS133(T-77)	QDTZ001SS133
D322	SWITCHING DIODE 1N4148	NDTZ001N4148
D323	ZENER DIODE MTZJT-7710B	QDTB00MTZJ10
D323	ZENER DIODE DZ-10BSBT265	NDTB00DZ10BS
D326	SWITCHING DIODE 1SS133(T-77)	QDTZ001SS133
D326	SWITCHING DIODE 1N4148	NDTZ001N4148
D327	ZENER DIODE MTZJT-778.2B	QDTB0MTZJ8R2
D327	ZENER DIODE DZ-8.2BSBT265	NDTB0DZ8R2BS
D351	SWITCHING DIODE 1SS133(T-77)	QDTZ001SS133
D351	SWITCHING DIODE 1N4148	NDTZ001N4148
D352	SWITCHING DIODE 1SS133(T-77)	QDTZ001SS133
D352	SWITCHING DIODE 1N4148	NDTZ001N4148
D353	SWITCHING DIODE 1SS133(T-77)	QDTZ001SS133
D353	SWITCHING DIODE 1N4148	NDTZ001N4148
D481	SWITCHING DIODE 1SS133(T-77)	QDTZ001SS133
D481	SWITCHING DIODE 1N4148	NDTZ001N4148
D525	ZENER DIODE MTZJT-7720B	QDTB00MTZJ20
D525	ZENER DIODE DZ-20BSBT265	NDTB00DZ20BS
D526	SWITCHING DIODE 1SS133(T-77)	QDTZ001SS133
D526	SWITCHING DIODE 1N4148	NDTZ001N4148
D532	DIODE 1N5397-B	NDLZ001N5397
D532	RECTIFIER DIODE ERA15-02	AERA1502****
D552	ZENER DIODE MTZJT-7715B	QDTB00MTZJ15
D552	ZENER DIODE DZ-15BSBT265	NDTB00DZ15BS
D558	SWITCHING DIODE 1SS133(T-77)	QDTZ001SS133
D558	SWITCHING DIODE 1N4148	NDTZ001N4148
D571	DIODE FR104-B	NDLZ000FR104
D571	RECTIFIER DIODE ERA22-02	QDPZ0ERA2202
D571	RECTIFIER DIODE 10ELS2	QDQZ0010ELS2
D572!	RECTIFIER DIODE ERA22-02	QDPZ0ERA2202
D572!	RECTIFIER DIODE 10ELS2	QDQZ0010ELS2
D573	RECTIFIER DIODE ERA22-02	QDPZ0ERA2202
D573	RECTIFIER DIODE 10ELS2	QDQZ0010ELS2
D580	DIODE ERD07-15	QDLZ0ERD0715
D582	FAST RECOVERY DIODE ERD38-06	QDQZ0ERD3806
D583	SWITCHING DIODE 1SS133(T-77)	QDTZ001SS133
D583	SWITCHING DIODE 1N4148	NDTZ001N4148
D584	SWITCHING DIODE 1SS133(T-77)	QDTZ001SS133
D584	SWITCHING DIODE 1N4148	NDTZ001N4148
D585	SWITCHING DIODE 1SS133(T-77)	QDTZ001SS133
D585	SWITCHING DIODE 1N4148	NDTZ001N4148
D586	SWITCHING DIODE 1SS133(T-77)	QDTZ001SS133
D586	SWITCHING DIODE 1N4148	NDTZ001N4148
D587	ZENER DIODE MTZJT-776.8B	QDTB0MTZJ6R8
D587	ZENER DIODE DZ-6.8BSBT265	NDTB0DZ6R8BS
D588	SWITCHING DIODE 1SS133(T-77)	QDTZ001SS133
D588	SWITCHING DIODE 1N4148	NDTZ001N4148
D591	ZENER DIODE MTZJT-7736B	QDTB00MTZJ36
D591	ZENER DIODE DZ-36BSBT265	NDTB00DZ36BS
D595	SWITCHING DIODE 1SS133(T-77)	QDTZ001SS133
D595	SWITCHING DIODE 1N4148	NDTZ001N4148
D597	ZENER DIODE MTZJT-776.8B	QDTB0MTZJ6R8
D597	ZENER DIODE DZ-6.8BSBT265	NDTB0DZ6R8BS
D605!	DIODE 1N5406	NDLZ001N5406
D605!	DIODE ERC04-06L3	QD4Z0ERC0406
D606!	DIODE 1N5406	NDLZ001N5406
D606!	DIODE ERC04-06L3	QD4Z0ERC0406
D607!	DIODE 1N5406	NDLZ001N5406

D607!	DIODE ERC04-06L3	QD4Z0ERC0406
D608!	DIODE 1N5406	NDLZ001N5406
D608!	DIODE ERC04-06L3	QD4Z0ERC0406
D609	SWITCHING DIODE 1SS133(T-77)	QDTZ001SS133
D609	SWITCHING DIODE 1N4148	NDTZ001N4148
D611	ZENER DIODE MTZJT-7715B	QDTB00MTZJ15
D611	ZENER DIODE DZ-15BSBT265	NDTB00DZ15BS
D615!	SWITCHING DIODE 1N4148 T-77	QDTZ001N4148
D621	ZENER DIODE MTZJT-777.5B	QDTB0MTZJ7R5
D621	ZENER DIODE DZ-7.5BSBT265	NDTB0DZ7R5BS
D622	SWITCHING DIODE 1SS133(T-77)	QDTZ001SS133
D622	SWITCHING DIODE 1N4148	NDTZ001N4148
D641	SWITCHING DIODE 1SS133(T-77)	QDTZ001SS133
D641	SWITCHING DIODE 1N4148	NDTZ001N4148
D642	SWITCHING DIODE 1SS133(T-77)	QDTZ001SS133
D642	SWITCHING DIODE 1N4148	NDTZ001N4148
D651!	FAST RECOVERY DIODE 30DF6	QDWZ00030DF6
D651!	FAST RECOVERY DIODE FE201-6	QDLZ00FE2016
D652!	DIODE FR154	NDLZ000FR154
D652!	FAST RECOVERY DIODE ERB44-02	QDPZ0ERB4402
D653!	DIODE FR154	NDLZ000FR154
D653!	FAST RECOVERY DIODE ERB44-02	QDPZ0ERB4402
D654	SWITCHING DIODE 1SS133(T-77)	QDTZ001SS133
D654	SWITCHING DIODE 1N4148	NDTZ001N4148
D655!	DIODE FR154	NDLZ000FR154
D655!	FAST RECOVERY DIODE ERB44-02	QDPZ0ERB4402
D657!	DIODE 1ZC36	QDQZ0001ZC36
D660	SWITCHING DIODE 1SS133(T-77)	QDTZ001SS133
D660	SWITCHING DIODE 1N4148	NDTZ001N4148
D661	SWITCHING DIODE 1SS133(T-77)	QDTZ001SS133
D661	SWITCHING DIODE 1N4148	NDTZ001N4148
D662!	ZENER DIODE MTZJT-776.8B	QDTB0MTZJ6R8
D662!	ZENER DIODE DZ-6.8BSBT265	NDTB0DZ6R8BS
D666	ZENER DIODE MTZJT-7736B	QDTB00MTZJ36
D666	ZENER DIODE DZ-36BSBT265	NDTB00DZ36BS
D671	SWITCHING DIODE 1SS133(T-77)	QDTZ001SS133
D671	SWITCHING DIODE 1N4148	NDTZ001N4148
D672	PCB JUMPER D0.6-P5.0	JW5.0T
D673	SWITCHING DIODE 1SS133(T-77)	QDTZ001SS133
D673	SWITCHING DIODE 1N4148	NDTZ001N4148
D681	ZENER DIODE MTZJT-779.1B	QDTB0MTZJ9R1
D681	ZENER DIODE DZ-9.1BSBT265	NDTB0DZ9R1BS
D683	SCHOTTKY BARRIER DIODE ERA81-004	QDPZERA81004
D691	SWITCHING DIODE 1SS133(T-77)	QDTZ001SS133
D691	SWITCHING DIODE 1N4148	NDTZ001N4148
D695	ZENER DIODE MTZJT-778.2B	QDTB0MTZJ8R2
D695	ZENER DIODE DZ-8.2BSBT265	NDTB0DZ8R2BS
D696	SWITCHING DIODE 1SS133(T-77)	QDTZ001SS133
D696	SWITCHING DIODE 1N4148	NDTZ001N4148
D826	SWITCHING DIODE 1SS133(T-77)	QDTZ001SS133
D826	SWITCHING DIODE 1N4148	NDTZ001N4148
D838	ZENER DIODE MTZJT-7710B	QDTB00MTZJ10
D838	ZENER DIODE DZ-10BSBT265	NDTB00DZ10BS
D841	SWITCHING DIODE 1SS133(T-77)	QDTZ001SS133
D841	SWITCHING DIODE 1N4148	NDTZ001N4148
D842	ZENER DIODE MTZJT-775.1B	QDTB0MTZJ5R1
D842	ZENER DIODE DZ-5.1BSBT265	NDTB0DZ5R1BS
D845	SWITCHING DIODE 1SS133(T-77)	QDTZ001SS133

D845	SWITCHING DIODE 1N4148	NDTZ001N4148
F601!	FUSE 4A/125V 237 TYPE	PAGJ20CAG402
F601!	FUSE STC4A125V U/CT	PAGE20CW3402
F601!	FUSE 4.00A/125V	PAGG20CNG402
FH601	FUSE HOLDER MSF-015	XH01Z00LY001
FH601	FUSE HOLDER FH-V-03078	XH01Z00DK001
FH601	HOLDER, FUSE CNT41-0014	1790424
FH602	FUSE HOLDER MSF-015	XH01Z00LY001
FH602	FUSE HOLDER FH-V-03078	XH01Z00DK001
FH602	HOLDER, FUSE CNT41-0014	1790424
GP641!	GAP. FNR-G3.10D	FAZ000LD6005
IC31	IC:VIF/SIF DETECTOR M61111FP	QSZBA0SMB010
IC111!	IC M61272M8-054FP	QSZAA0RMB130
IC151	IC:MEMORY S524C20D21	NSZBA0SSM028
IC151	IC:MEMORY AT24C02N-10SC	NSMMA0SAZ012
IC151	IC(EEPROM) M24C02-MN6	NSMMA0SSS028
IC151	IC:MEMORY BR24C02F-W	QSMBA0SRM003
IC151	IC:MEMORY BR24C02F	QSMMA0SRM003
IC151	IC:EEPROM CAT24WC02JI	NSZBA0SBG001
IC151	IC(EEP-ROM) M24C02-WMN6	NSZAA0SSS004
IC401	IC:USA STEREO DECODER LA7765	QSZBA0SSY003
IC481	IC:SWITCHING TC4052BF(EL)	QSZBA0TTS096
IC481	IC:SWITCHING CD4052BCSJX	NSZBA0TF3079
IC551!	IC:VERTICAL OUTPUT LA78041	QSZBA0SSY006
IC551!	IC:VERTICAL OUTPUT LA78045	QSZBA0SSY004
IC601!	PHOTOCOUPLER PS2501-1W	QPEW0PS25011
IC601!	PHOTO COUPLER PS2501-1L	QPEL0PS25011
IC601!	PHOTOCOUPLER LTV-817B-F	NPEB0LTV817F
IC601!	PHOTOCOUPLER LTV-817C-F	NPEC0LTV817F
IC802	AUDIO POWER IC AN17805A	QSZBA0SMS007
JK701	RCA JACK(YELLOW) MTJ-032-06B-20	JXRL010LY050
JK701	RCA JACK 1P AV-8.4-9Y	JXRL010RP010
JK702	RCA JACK(WHITE) MTJ-032-06B-22	JXRL010LY052
JK702	RCA JACK 1P AV-8.4-9W	JXRL010RP011
JK703	RCA JACK(RED) MTJ-032-06B-21	JXRL010LY051
JK703	RCA JACK 1P AV-8.4-9R	JXRL010RP006
JK704	RCA JACK 3P (SW) MSP-213-V2-432	JYRL030LY008
JK705	RCA JACK 3P MSP-213-V1-432 PBSN	JXRL030LY048
JK801	HEADPHONE JACK MSJ-035-10A B	JYSL020LY002
JS102	PCB JUMPER D0.6-P5.0	JW5.0T
JS104	PCB JUMPER D0.6-P5.0	JW5.0T
JS105	PCB JUMPER D0.6-P5.0	JW5.0T
JS342	PCB JUMPER D0.6-P5.0	JW5.0T
JS551	PCB JUMPER D0.6-P5.0	JW5.0T
JS704	PCB JUMPER D0.6-P5.0	JW5.0T
JS856	PCB JUMPER D0.6-P5.0	JW5.0T
L1	SCREW, B-TIGHT M3X8 BIND HEAD+	GBMB3080
L1	SCREW, B-TIGHT M3X8 BIND HEAD+	GBMB3080
L1	SCREW, B-TIGHT M3X8 BIND HEAD+	GBMB3080
L1	SCREW, B-TIGHT M3X8 BIND HEAD+	GBMB3080
L1	PCB JUMPER D0.6-P5.0	JW5.0T
L3	INDUCTOR 22UH-K-5FT	LLARKBSTU220
L3	INDUCTOR 22UH-K	LLARKDQKA220
L32	INDUCTOR 15UH-J-26T	LLAXJATTU150
L32	INDUCTOR 15UH-K-26T	LLAXKDTKA150
L33	INDUCTOR 22UH-J-26T	LLAXJATTU220
L33	INDUCTOR 22UH-K-26T	LLAXKDTKA220
L51	INDUCTOR 100UH-K-5FT	LLARKBSTU101

L51	INDUCTOR 100UH-K	LLARKDQKA101
L111	INDUCTOR 22UH-K-5FT	LLARKBSTU220
L111	INDUCTOR 22UH-K	LLARKDQKA220
L301	INDUCTOR 100UH-K-5FT	LLARKBSTU101
L301	INDUCTOR 100UH-K	LLARKDQKA101
L341	PCB JUMPER D0.6-P5.0	JW5.0T
L342	PCB JUMPER D0.6-P5.0	JW5.0T
L561	LINEARITY COIL ELH5L6136N	LLBD00PMS008
L562	LINEARITY COIL ST02LN	LLBD00ZY2003
L562	CHOKE COIL ELC13B102L	LLC102KMS001
L562	CHOKE COIL CSA-LF048	LLBD00ZSA003
L601!	LINE FILTER JLB2808	LLBG00ZXB004
L601!	LINE FILTER MS036	LLBG00ZY2009
L601!	LINE FILTER CSA-LF032	LLBG00ZSA007
L692	CHOKE COIL 47UH-K	LLBD00PKV007
L692	POT COIL 47UH K	LLBD**DMM001
L692	POT COIL 47UH K	LLBD00DQE001
PS691!	THERMISTOR ZPB45BL7R0A	QNZZ45BL7R0A
Q31	TRANSISTOR 2SC2785(F)	QQSF02SC2785
Q31	TRANSISTOR 2SC2785(H)	QQSH02SC2785
Q31	TRANSISTOR 2SC2785(J)	QQSJ02SC2785
Q31	TRANSISTOR KTC3199(GR)	NQS10KTC3199
Q31	TRANSISTOR KTC3198(GR)	NQS40KTC3198
Q31	TRANSISTOR 2SC3331(T)-AANP	2SC3331TZ
Q31	TRANSISTOR 2SC3331(U)-AANP	2SC3331UZ
Q31	TRANSISTOR 2SC1815-GR(TPE2)	QQS102SC1815
Q111	TRANSISTOR 2SC2785(F)	QQSF02SC2785
Q111	TRANSISTOR 2SC2785(H)	QQSH02SC2785
Q111	TRANSISTOR 2SC2785(J)	QQSJ02SC2785
Q111	TRANSISTOR KTC3199(GR)	NQS10KTC3199
Q111	TRANSISTOR KTC3198(GR)	NQS40KTC3198
Q111	TRANSISTOR 2SC3331(T)-AANP	2SC3331TZ
Q111	TRANSISTOR 2SC3331(U)-AANP	2SC3331UZ
Q111	TRANSISTOR 2SC1815-GR(TPE2)	QQS102SC1815
Q321	TRANSISTOR 2SC2785(F)	QQSF02SC2785
Q321	TRANSISTOR 2SC2785(H)	QQSH02SC2785
Q321	TRANSISTOR 2SC2785(J)	QQSJ02SC2785
Q321	TRANSISTOR KTC3199(GR)	NQS10KTC3199
Q321	TRANSISTOR KTC3198(GR)	NQS40KTC3198
Q321	TRANSISTOR 2SC3331(T)-AANP	2SC3331TZ
Q321	TRANSISTOR 2SC3331(U)-AANP	2SC3331UZ
Q321	TRANSISTOR 2SC1815-GR(TPE2)	QQS102SC1815
Q411	TRANSISTOR 2SA1175(F)	QQSF02SA1175
Q411	TRANSISTOR KTA1267(GR)	NQS10KTA1267
Q411	TRANSISTOR KTA1266(GR)	NQS40KTA1266
Q411	TRANSISTOR 2SA1318(T)-AANP	2SA1318TZ
Q411	TRANSISTOR 2SA1318(U)-AANP	2SA1318UZ
Q411	TRANSISTOR 2SA1015-GR(TPE2)	QQS102SA1015
Q441	TRANSISTOR 2SA1175(F)	QQSF02SA1175
Q441	TRANSISTOR KTA1267(GR)	NQS10KTA1267
Q441	TRANSISTOR KTA1266(GR)	NQS40KTA1266
Q441	TRANSISTOR 2SA1318(T)-AANP	2SA1318TZ
Q441	TRANSISTOR 2SA1318(U)-AANP	2SA1318UZ
Q441	TRANSISTOR 2SA1015-GR(TPE2)	QQS102SA1015
Q481	TRANSISTOR 2SC2785(F)	QQSF02SC2785
Q481	TRANSISTOR 2SC2785(H)	QQSH02SC2785
Q481	TRANSISTOR 2SC2785(J)	QQSJ02SC2785
Q481	TRANSISTOR KTC3199(GR)	NQS10KTC3199

Q481	TRANSISTOR KTC3198(GR)	NQS40KTC3198
Q481	TRANSISTOR 2SC3331(T)-AANP	2SC3331TZ
Q481	TRANSISTOR 2SC3331(U)-AANP	2SC3331UZ
Q481	TRANSISTOR 2SC1815-GR(TPE2)	QQS102SC1815
Q482	TRANSISTOR 2SC2785(F)	QQSF02SC2785
Q482	TRANSISTOR 2SC2785(H)	QQSH02SC2785
Q482	TRANSISTOR 2SC2785(J)	QQSJ02SC2785
Q482	TRANSISTOR KTC3199(GR)	NQS10KTC3199
Q482	TRANSISTOR KTC3198(GR)	NQS40KTC3198
Q482	TRANSISTOR 2SC3331(T)-AANP	2SC3331TZ
Q482	TRANSISTOR 2SC3331(U)-AANP	2SC3331UZ
Q482	TRANSISTOR 2SC1815-GR(TPE2)	QQS102SC1815
Q531	TRANSISTOR 2SC2785(F)	QQSF02SC2785
Q531	TRANSISTOR 2SC2785(H)	QQSH02SC2785
Q531	TRANSISTOR 2SC2785(J)	QQSJ02SC2785
Q531	TRANSISTOR KTC3199(GR)	NQS10KTC3199
Q531	TRANSISTOR KTC3198(GR)	NQS40KTC3198
Q531	TRANSISTOR 2SC3331(T)-AANP	2SC3331TZ
Q531	TRANSISTOR 2SC3331(U)-AANP	2SC3331UZ
Q531	TRANSISTOR 2SC1815-GR(TPE2)	QQS102SC1815
Q532	TRANSISTOR 2SC2785(F)	QQSF02SC2785
Q532	TRANSISTOR 2SC2785(H)	QQSH02SC2785
Q532	TRANSISTOR 2SC2785(J)	QQSJ02SC2785
Q532	TRANSISTOR KTC3199(GR)	NQS10KTC3199
Q532	TRANSISTOR KTC3198(GR)	NQS40KTC3198
Q532	TRANSISTOR 2SC3331(T)-AANP	2SC3331TZ
Q532	TRANSISTOR 2SC3331(U)-AANP	2SC3331UZ
Q532	TRANSISTOR 2SC1815-GR(TPE2)	QQS102SC1815
Q551	TRANSISTOR 2SA1175(F)	QQSF02SA1175
Q551	TRANSISTOR KTA1267(GR)	NQS10KTA1267
Q551	TRANSISTOR KTA1266(GR)	NQS40KTA1266
Q551	TRANSISTOR 2SA1318(T)-AANP	2SA1318TZ
Q551	TRANSISTOR 2SA1318(U)-AANP	2SA1318UZ
Q551	TRANSISTOR 2SA1015-GR(TPE2)	QQS102SA1015
Q552	TRANSISTOR 2SD1666R	QQR02SD1666
Q552	TRANSISTOR 2SD1666S	QQR02SD1666
Q552	TRANSISTOR KTD2059(O)	NQ400KTD2059
Q552	TRANSISTOR KTD2059(Y)	NQ4Y0KTD2059
Q552	TRANSISTOR 2SD1825	Q2SD1825****
Q553	TRANSISTOR 2SC2785(F)	QQSF02SC2785
Q553	TRANSISTOR 2SC2785(H)	QQSH02SC2785
Q553	TRANSISTOR 2SC2785(J)	QQSJ02SC2785
Q553	TRANSISTOR KTC3199(GR)	NQS10KTC3199
Q553	TRANSISTOR KTC3198(GR)	NQS40KTC3198
Q553	TRANSISTOR 2SC3331(T)-AANP	2SC3331TZ
Q553	TRANSISTOR 2SC3331(U)-AANP	2SC3331UZ
Q553	TRANSISTOR 2SC1815-GR(TPE2)	QQS102SC1815
Q561	TRANSISTOR 2SC2785(F)	QQSF02SC2785
Q561	TRANSISTOR 2SC2785(H)	QQSH02SC2785
Q561	TRANSISTOR 2SC2785(J)	QQSJ02SC2785
Q561	TRANSISTOR KTC3199(GR)	NQS10KTC3199
Q561	TRANSISTOR KTC3198(GR)	NQS40KTC3198
Q561	TRANSISTOR 2SC3331(T)-AANP	2SC3331TZ
Q561	TRANSISTOR 2SC3331(U)-AANP	2SC3331UZ
Q561	TRANSISTOR 2SC1815-GR(TPE2)	QQS102SC1815
Q571!	TRANSISTOR 2SD2634	QQZ02SD2634
Q571!	TRANSISTOR TT2142	QQZ00TT2142
Q572	TRANSISTOR 2SC1627Y-TPE2	QQSY02SC1627

Q601!	FET 2SK3407	QFFZ02SK3407
Q602!	TRANSISTOR 2SC2120-O-TPE2	QQS002SC2120
Q602!	TRANSISTOR 2SC2120-Y(TPE2)	QQSY02SC2120
Q641	TRANSISTOR 2SA1175(F)	QQSF02SA1175
Q641	TRANSISTOR KTA1267(GR)	NQS10KTA1267
Q641	TRANSISTOR KTA1266(GR)	NQS40KTA1266
Q641	TRANSISTOR 2SA1318(T)-AANP	2SA1318TZ
Q641	TRANSISTOR 2SA1318(U)-AANP	2SA1318UZ
Q641	TRANSISTOR 2SA1015-GR(TPE2)	QQS102SA1015
Q662!	TRANSISTOR 2SC2785(F)	QQSF02SC2785
Q662!	TRANSISTOR 2SC2785(H)	QQSH02SC2785
Q662!	TRANSISTOR 2SC2785(J)	QQSJ02SC2785
Q662!	TRANSISTOR KTC3199(GR)	NQS10KTC3199
Q662!	TRANSISTOR KTC3198(GR)	NQS40KTC3198
Q662!	TRANSISTOR 2SC3331(T)-AANP	2SC3331TZ
Q662!	TRANSISTOR 2SC3331(U)-AANP	2SC3331UZ
Q662!	TRANSISTOR 2SC1815-GR(TPE2)	QQS102SC1815
Q671!	TRANSISTOR 2SA1175(F)	QQSF02SA1175
Q671!	TRANSISTOR KTA1267(GR)	NQS10KTA1267
Q671!	TRANSISTOR KTA1266(GR)	NQS40KTA1266
Q671!	TRANSISTOR 2SA1318(T)-AANP	2SA1318TZ
Q671!	TRANSISTOR 2SA1318(U)-AANP	2SA1318UZ
Q671!	TRANSISTOR 2SA1015-GR(TPE2)	QQS102SA1015
Q675	TRANSISTOR 2SC2785(F)	QQSF02SC2785
Q675	TRANSISTOR 2SC2785(H)	QQSH02SC2785
Q675	TRANSISTOR 2SC2785(J)	QQSJ02SC2785
Q675	TRANSISTOR KTC3199(GR)	NQS10KTC3199
Q675	TRANSISTOR KTC3198(GR)	NQS40KTC3198
Q675	TRANSISTOR 2SC3331(T)-AANP	2SC3331TZ
Q675	TRANSISTOR 2SC3331(U)-AANP	2SC3331UZ
Q675	TRANSISTOR 2SC1815-GR(TPE2)	QQS102SC1815
Q676	TRANSISTOR 2SC2785(F)	QQSF02SC2785
Q676	TRANSISTOR 2SC2785(H)	QQSH02SC2785
Q676	TRANSISTOR 2SC2785(J)	QQSJ02SC2785
Q676	TRANSISTOR KTC3199(GR)	NQS10KTC3199
Q676	TRANSISTOR KTC3198(GR)	NQS40KTC3198
Q676	TRANSISTOR 2SC3331(T)-AANP	2SC3331TZ
Q676	TRANSISTOR 2SC3331(U)-AANP	2SC3331UZ
Q676	TRANSISTOR 2SC1815-GR(TPE2)	QQS102SC1815
Q681!	TRANSISTOR 2SC2120-O-TPE2	QQS002SC2120
Q681!	TRANSISTOR 2SC2120-Y(TPE2)	QQSY02SC2120
Q681!	TRANSISTOR KTC3203(Y)	NQSY0KTC3203
Q682!	TRANSISTOR 2SC2120-O-TPE2	QQS002SC2120
Q682!	TRANSISTOR 2SC2120-Y(TPE2)	QQSY02SC2120
Q682!	TRANSISTOR KTC3203(Y)	NQSY0KTC3203
Q683!	TRANSISTOR 2SC2120-O-TPE2	QQS002SC2120
Q683!	TRANSISTOR 2SC2120-Y(TPE2)	QQSY02SC2120
Q683!	TRANSISTOR KTC3203(Y)	NQSY0KTC3203
Q696	RES. BUILT-IN TRANSISTOR BA1F4M-T	QQS200BA1F4M
Q696	RES. BUILT-IN TRANSISTOR KRC103M	NQS20KRC103M
Q761	TRANSISTOR 2SC2785(F)	QQSF02SC2785
Q761	TRANSISTOR 2SC2785(H)	QQSH02SC2785
Q761	TRANSISTOR 2SC2785(J)	QQSJ02SC2785
Q761	TRANSISTOR KTC3199(GR)	NQS10KTC3199
Q761	TRANSISTOR KTC3198(GR)	NQS40KTC3198
Q761	TRANSISTOR 2SC3331(T)-AANP	2SC3331TZ
Q761	TRANSISTOR 2SC3331(U)-AANP	2SC3331UZ
Q761	TRANSISTOR 2SC1815-GR(TPE2)	QQS102SC1815

Q766	TRANSISTOR 2SC2785(F)	QQSF02SC2785
Q766	TRANSISTOR 2SC2785(H)	QQSH02SC2785
Q766	TRANSISTOR 2SC2785(J)	QQSJ02SC2785
Q766	TRANSISTOR KTC3199(GR)	NQS10KTC3199
Q766	TRANSISTOR KTC3198(GR)	NQS40KTC3198
Q766	TRANSISTOR 2SC3331(T)-AANP	2SC3331TZ
Q766	TRANSISTOR 2SC3331(U)-AANP	2SC3331UZ
Q766	TRANSISTOR 2SC1815-GR(TPE2)	QQS102SC1815
Q782	TRANSISTOR 2SA1175(F)	QQSF02SA1175
Q782	TRANSISTOR KTA1267(GR)	NQS10KTA1267
Q782	TRANSISTOR KTA1266(GR)	NQS40KTA1266
Q782	TRANSISTOR 2SA1318(T)-AANP	2SA1318TZ
Q782	TRANSISTOR 2SA1318(U)-AANP	2SA1318UZ
Q782	TRANSISTOR 2SA1015-GR(TPE2)	QQS102SA1015
Q791	TRANSISTOR 2SC2785(F)	QQSF02SC2785
Q791	TRANSISTOR 2SC2785(H)	QQSH02SC2785
Q791	TRANSISTOR 2SC2785(J)	QQSJ02SC2785
Q791	TRANSISTOR KTC3199(GR)	NQS10KTC3199
Q791	TRANSISTOR KTC3198(GR)	NQS40KTC3198
Q791	TRANSISTOR 2SC3331(T)-AANP	2SC3331TZ
Q791	TRANSISTOR 2SC3331(U)-AANP	2SC3331UZ
Q791	TRANSISTOR 2SC1815-GR(TPE2)	QQS102SC1815
Q792	TRANSISTOR 2SC2785(F)	QQSF02SC2785
Q792	TRANSISTOR 2SC2785(H)	QQSH02SC2785
Q792	TRANSISTOR 2SC2785(J)	QQSJ02SC2785
Q792	TRANSISTOR KTC3199(GR)	NQS10KTC3199
Q792	TRANSISTOR KTC3198(GR)	NQS40KTC3198
Q792	TRANSISTOR 2SC3331(T)-AANP	2SC3331TZ
Q792	TRANSISTOR 2SC3331(U)-AANP	2SC3331UZ
Q792	TRANSISTOR 2SC1815-GR(TPE2)	QQS102SC1815
Q825	TRANSISTOR 2SC2785(F)	QQSF02SC2785
Q825	TRANSISTOR 2SC2785(H)	QQSH02SC2785
Q825	TRANSISTOR 2SC2785(J)	QQSJ02SC2785
Q825	TRANSISTOR KTC3199(GR)	NQS10KTC3199
Q825	TRANSISTOR KTC3198(GR)	NQS40KTC3198
Q825	TRANSISTOR 2SC3331(T)-AANP	2SC3331TZ
Q825	TRANSISTOR 2SC3331(U)-AANP	2SC3331UZ
Q825	TRANSISTOR 2SC1815-GR(TPE2)	QQS102SC1815
Q831!	TRANSISTOR 2SB892(S)	QQSS002SB892
Q831!	TRANSISTOR 2SB892(T)	QQST002SB892
Q832	TRANSISTOR 2SC2785(F)	QQSF02SC2785
Q832	TRANSISTOR 2SC2785(H)	QQSH02SC2785
Q832	TRANSISTOR 2SC2785(J)	QQSJ02SC2785
Q832	TRANSISTOR KTC3199(GR)	NQS10KTC3199
Q832	TRANSISTOR KTC3198(GR)	NQS40KTC3198
Q832	TRANSISTOR 2SC3331(T)-AANP	2SC3331TZ
Q832	TRANSISTOR 2SC3331(U)-AANP	2SC3331UZ
Q832	TRANSISTOR 2SC1815-GR(TPE2)	QQS102SC1815
Q833!	TRANSISTOR 2SC2785(F)	QQSF02SC2785
Q833!	TRANSISTOR 2SC2785(H)	QQSH02SC2785
Q833!	TRANSISTOR 2SC2785(J)	QQSJ02SC2785
Q833!	TRANSISTOR KTC3199(GR)	NQS10KTC3199
Q833!	TRANSISTOR KTC3198(GR)	NQS40KTC3198
Q833!	TRANSISTOR 2SC3331(T)-AANP	2SC3331TZ
Q833!	TRANSISTOR 2SC3331(U)-AANP	2SC3331UZ
Q833!	TRANSISTOR 2SC1815-GR(TPE2)	QQS102SC1815
R3	PCB JUMPER D0.6-P5.0	JW5.0T
R4	CARBON RES. 1/4W J 100 OHM	RCX4JATZ0101

R4	CARBON RES. 1/6W J 100 OHM	RCX6JATZ0101
R5	CARBON RES. 1/4W J 100 OHM	RCX4JATZ0101
R5	CARBON RES. 1/6W J 100 OHM	RCX6JATZ0101
R21	CARBON RES. 1/4W J 6.8K OHM	RCX4JATZ0682
R31	CARBON RES. 1/4W J 2.2K OHM	RCX4JATZ0222
R32	CARBON RES. 1/4W J 390 OHM	RCX4JATZ0391
R32	CARBON RES. 1/6W J 390 OHM	RCX6JATZ0391
R33	CARBON RES. 1/4W J 270 OHM	RCX4JATZ0271
R33	CARBON RES. 1/6W J 270 OHM	RCX6JATZ0271
R34	CARBON RES. 1/4W J 180 OHM	RCX4JATZ0181
R34	CARBON RES. 1/6W J 180 OHM	RCX6JATZ0181
R36	CARBON RES. 1/4W J 10K OHM	RCX4JATZ0103
R37	CARBON RES. 1/4W J 470 OHM	RCX4JATZ0471
R37	CARBON RES. 1/6W J 470 OHM	RCX6JATZ0471
R41	CARBON RES. 1/4W J 2.2K OHM	RCX4JATZ0222
R42	CARBON RES. 1/4W J 56K OHM	RCX4JATZ0563
R43	CARBON RES. 1/4W J 12K OHM	RCX4JATZ0123
R51	CARBON RES. 1/4W J 220K OHM	RCX4JATZ0224
R52	CARBON RES. 1/4W J 220K OHM	RCX4JATZ0224
R54	CARBON RES. 1/4W J 22K OHM	RCX4JATZ0223
R102	CARBON RES. 1/4W J 2.2K OHM	RCX4JATZ0222
R103	CARBON RES. 1/4W J 1.8K OHM	RCX4JATZ0182
R104	CARBON RES. 1/4W J 3.3K OHM	RCX4JATZ0332
R105	CARBON RES. 1/4W J 4.7K OHM	RCX4JATZ0472
R106	CARBON RES. 1/4W J 8.2K OHM	RCX4JATZ0822
R111	CARBON RES. 1/4W J 100 OHM	RCX4JATZ0101
R111	CARBON RES. 1/6W J 100 OHM	RCX6JATZ0101
R112	CARBON RES. 1/4W J 10K OHM	RCX4JATZ0103
R113	CARBON RES. 1/4W J 470K OHM	RCX4JATZ0474
R114	CARBON RES. 1/4W J 1K OHM	RCX4JATZ0102
R114	CARBON RES. 1/6W J 1K OHM	RCX6JATZ0102
R116	CARBON RES. 1/4W J 1K OHM	RCX4JATZ0102
R116	CARBON RES. 1/6W J 1K OHM	RCX6JATZ0102
R130	CARBON RES. 1/4W J 10K OHM	RCX4JATZ0103
R132	PCB JUMPER D0.6-P5.0	JW5.0T
R133	PCB JUMPER D0.6-P5.0	JW5.0T
R135	CARBON RES. 1/4W J 2.2K OHM	RCX4JATZ0222
R136	CARBON RES. 1/4W J 100K OHM	RCX4JATZ0104
R137	CARBON RES. 1/4W J 100 OHM	RCX4JATZ0101
R137	CARBON RES. 1/6W J 100 OHM	RCX6JATZ0101
R138	CARBON RES. 1/4W J 220K OHM	RCX4JATZ0224
R139	CARBON RES. 1/4W J 22K OHM	RCX4JATZ0223
R140	CARBON RES. 1/4W J 1K OHM	RCX4JATZ0102
R140	CARBON RES. 1/6W J 1K OHM	RCX6JATZ0102
R141	PCB JUMPER D0.6-P5.0	JW5.0T
R151	CARBON RES. 1/4W J 4.7K OHM	RCX4JATZ0472
R155	CARBON RES. 1/4W J 100 OHM	RCX4JATZ0101
R155	CARBON RES. 1/6W J 100 OHM	RCX6JATZ0101
R156	CARBON RES. 1/4W J 1K OHM	RCX4JATZ0102
R156	CARBON RES. 1/6W J 1K OHM	RCX6JATZ0102
R161	CARBON RES. 1/4W J 10K OHM	RCX4JATZ0103
R162	CARBON RES. 1/4W J 10K OHM	RCX4JATZ0103
R163	CARBON RES. 1/4W J 6.8K OHM	RCX4JATZ0682
R164	CARBON RES. 1/4W J 10K OHM	RCX4JATZ0103
R166	CARBON RES. 1/4W J 4.7K OHM	RCX4JATZ0472
R168	CARBON RES. 1/4W J 4.7K OHM	RCX4JATZ0472
R170	CARBON RES. 1/4W J 6.8K OHM	RCX4JATZ0682
R171	CARBON RES. 1/4W J 3.3K OHM	RCX4JATZ0332

R172	PCB JUMPER D0.6-P5.0	JW5.0T
R173	CARBON RES. 1/4W J 4.7K OHM	RCX4JATZ0472
R301	CARBON RES. 1/4W J 6.8K OHM	RCX4JATZ0682
R302	CARBON RES. 1/4W J 100 OHM	RCX4JATZ0101
R302	CARBON RES. 1/6W J 100 OHM	RCX6JATZ0101
R303	CARBON RES. 1/4W J 100 OHM	RCX4JATZ0101
R303	CARBON RES. 1/6W J 100 OHM	RCX6JATZ0101
R322	PCB JUMPER D0.6-P5.0	JW5.0T
R323	CARBON RES. 1/4W J 2.2K OHM	RCX4JATZ0222
R326	CARBON RES. 1/4W J 100 OHM	RCX4JATZ0101
R326	CARBON RES. 1/6W J 100 OHM	RCX6JATZ0101
R327	PCB JUMPER D0.6-P5.0	JW5.0T
R328	CARBON RES. 1/4W J 3.3K OHM	RCX4JATZ0332
R329	CARBON RES. 1/4W J 47K OHM	RCX4JATZ0473
R330	CARBON RES. 1/4W J 1K OHM	RCX4JATZ0102
R330	CARBON RES. 1/6W J 1K OHM	RCX6JATZ0102
R331	PCB JUMPER D0.6-P5.0	JW5.0T
R333	CARBON RES. 1/4W J 330 OHM	RCX4JATZ0331
R333	CARBON RES. 1/6W J 330 OHM	RCX6JATZ0331
R342	PCB JUMPER D0.6-P5.0	JW5.0T
R344	CARBON RES. 1/4W J 6.8K OHM	RCX4JATZ0682
R345	CARBON RES. 1/4W J 10K OHM	RCX4JATZ0103
R346	CARBON RES. 1/4W J 470 OHM	RCX4JATZ0471
R346	CARBON RES. 1/6W J 470 OHM	RCX6JATZ0471
R347	PCB JUMPER D0.6-P5.0	JW5.0T
R348	CARBON RES. 1/4W J 27K OHM	RCX4JATZ0273
R355	CARBON RES. 1/4W J 33K OHM	RCX4JATZ0333
R356	CARBON RES. 1/4W J 220 OHM	RCX4JATZ0221
R356	CARBON RES. 1/6W J 220 OHM	RCX6JATZ0221
R357	CARBON RES. 1/4W J 220 OHM	RCX4JATZ0221
R357	CARBON RES. 1/6W J 220 OHM	RCX6JATZ0221
R358	CARBON RES. 1/4W J 220 OHM	RCX4JATZ0221
R358	CARBON RES. 1/6W J 220 OHM	RCX6JATZ0221
R362	CARBON RES. 1/4W J 100 OHM	RCX4JATZ0101
R362	CARBON RES. 1/6W J 100 OHM	RCX6JATZ0101
R402	CARBON RES. 1/4W J 5.6K OHM	RCX4JATZ0562
R403	PCB JUMPER D0.6-P5.0	JW5.0T
R405	CARBON RES. 1/4W J 3.3K OHM	RCX4JATZ0332
R406	CARBON RES. 1/4W J 15K OHM	RCX4JATZ0153
R407	CARBON RES. 1/4W J 6.8K OHM	RCX4JATZ0682
R408	CARBON RES. 1/4W J 10K OHM	RCX4JATZ0103
R409	CARBON RES. 1/4W J 10K OHM	RCX4JATZ0103
R412	CARBON RES. 1/4W J 10K OHM	RCX4JATZ0103
R421	CARBON RES. 1/4W J 4.7K OHM	RCX4JATZ0472
R422	CARBON RES. 1/4W J 4.7K OHM	RCX4JATZ0472
R432	CARBON RES. 1/4W J 220 OHM	RCX4JATZ0221
R432	CARBON RES. 1/6W J 220 OHM	RCX6JATZ0221
R435	CARBON RES. 1/4W J 470 OHM	RCX4JATZ0471
R435	CARBON RES. 1/6W J 470 OHM	RCX6JATZ0471
R436	CARBON RES. 1/4W J 10K OHM	RCX4JATZ0103
R441	CARBON RES. 1/4W J 10K OHM	RCX4JATZ0103
R442	CARBON RES. 1/4W J 10K OHM	RCX4JATZ0103
R443	CARBON RES. 1/4W J 10K OHM	RCX4JATZ0103
R445	CARBON RES. 1/4W J 10K OHM	RCX4JATZ0103
R481	CARBON RES. 1/4W J 10K OHM	RCX4JATZ0103
R482	CARBON RES. 1/4W J 22K OHM	RCX4JATZ0223
R483	CARBON RES. 1/4W J 10K OHM	RCX4JATZ0103
R484	CARBON RES. 1/4W J 22K OHM	RCX4JATZ0223

R490	PCB JUMPER D0.6-P5.0	JW5.0T
R521	CARBON RES. 1/4W J 680 OHM	RCX4JATZ0681
R521	CARBON RES. 1/6W J 680 OHM	RCX6JATZ0681
R522	CARBON RES. 1/4W J 680 OHM	RCX4JATZ0681
R522	CARBON RES. 1/6W J 680 OHM	RCX6JATZ0681
R523	CARBON RES. 1/4W J 680 OHM	RCX4JATZ0681
R523	CARBON RES. 1/6W J 680 OHM	RCX6JATZ0681
R527	CARBON RES. 1/4W J 6.8K OHM	RCX4JATZ0682
R530	CARBON RES. 1/4W J 22K OHM	RCX4JATZ0223
R531	CARBON RES. 1/4W J 22K OHM	RCX4JATZ0223
R532	CARBON RES. 1/4W J 1.8K OHM	RCX4JATZ0182
R533	CARBON RES. 1/4W J 3.3 OHM	RCX4JATZ03R3
R533	CARBON RES. 1/6W J 3.3 OHM	RCX6JATZ03R3
R534	CARBON RES. 1/4W J 22K OHM	RCX4JATZ0223
R535	CARBON RES. 1/4W J 2.7K OHM	RCX4JATZ0272
R536	CARBON RES. 1/4W J 470 OHM	RCX4JATZ0471
R536	CARBON RES. 1/6W J 470 OHM	RCX6JATZ0471
R537	CARBON RES. 1/4W J 68K OHM	RCX4JATZ0683
R538	CARBON RES. 1/4W J 22K OHM	RCX4JATZ0223
R540	CARBON RES. 1/4W J 2.7K OHM	RCX4JATZ0272
R541	CARBON RES. 1/4W J 2.7K OHM	RCX4JATZ0272
R542	CARBON RES. 1/4W J 2.7 OHM	RCX4JATZ02R7
R542	CARBON RES. 1/6W J 2.7 OHM	RCX6JATZ02R7
R543	CARBON RES. 1/4W J 2.7 OHM	RCX4JATZ02R7
R543	CARBON RES. 1/6W J 2.7 OHM	RCX6JATZ02R7
R544	CARBON RES. 1/4W J 2.7 OHM	RCX4JATZ02R7
R544	CARBON RES. 1/6W J 2.7 OHM	RCX6JATZ02R7
R549!	METAL OXIDE FILM RES. 1W J 12 OHM	RN01120ZU001
R549!	METAL OXIDE FILM RES. 1W J 12 OHM	RN01200DP003
R550	METAL OXIDE FILM RES. 1W J 12 OHM	RN01120ZU001
R550	METAL OXIDE FILM RES. 1W J 12 OHM	RN01200DP003
R551	METAL OXIDE FILM RES. 2W J 680 OHM	RN02681ZU001
R551	METAL OXIDE FILM RES. 2W J 680 OHM	RN02681DP004
R552	METAL OXIDE FILM RES. 2W J 8.2 OHM	RN028R2ZU001
R552	METAL OXIDE FILM RES. 2W J 8.2 OHM	RN028R2DP004
R553	CARBON RES. 1/4W J 2.2K OHM	RCX4JATZ0222
R554	CARBON RES. 1/4W J 3.9K OHM	RCX4JATZ0392
R555	CARBON RES. 1/4W J 2.2K OHM	RCX4JATZ0222
R556	CARBON RES. 1/4W J 47K OHM	RCX4JATZ0473
R557	CARBON RES. 1/4W J 18K OHM	RCX4JATZ0183
R558	CARBON RES. 1/4W J 220 OHM	RCX4JATZ0221
R558	CARBON RES. 1/6W J 220 OHM	RCX6JATZ0221
R559	CARBON RES. 1/4W J 6.8K OHM	RCX4JATZ0682
R560	CARBON RES. 1/4W J 2.2K OHM	RCX4JATZ0222
R561	CARBON RES. 1/4W J 1.2K OHM	RCX4JATZ0122
R562	CARBON RES. 1/4W J 100K OHM	RCX4JATZ0104
R563	CARBON RES. 1/4W J 10K OHM	RCX4JATZ0103
R564	CARBON RES. 1/4W J 150K OHM	RCX4JATZ0154
R565	CARBON RES. 1/4W J 22K OHM	RCX4JATZ0223
R566	CARBON RES. 1/4W J 8.2K OHM	RCX4JATZ0822
R568	CARBON RES. 1/4W J 1K OHM	RCX4JATZ0102
R568	CARBON RES. 1/6W J 1K OHM	RCX6JATZ0102
R569	CARBON RES. 1/4W J 2.7K OHM	RCX4JATZ0272
R571	METAL OXIDE FILM RES. 2W J 1.2K OHM	RN02122ZU001
R571	METAL OXIDE FILM RES. 2W J 1.2K OHM	RN02122DP004
R572	METAL OXIDE FILM RES. 2W J 1.2K OHM	RN02122ZU001
R572	METAL OXIDE FILM RES. 2W J 1.2K OHM	RN02122DP004
R575	CARBON RES. 1/4W J 15 OHM	RCX4JATZ0150

R575	CARBON RES. 1/6W J 15 OHM	RCX6JATZ0150
R576	CARBON RES. 1/4W J 15 OHM	RCX4JATZ0150
R576	CARBON RES. 1/6W J 15 OHM	RCX6JATZ0150
R577	CARBON RES. 1/4W J 15 OHM	RCX4JATZ0150
R577	CARBON RES. 1/6W J 15 OHM	RCX6JATZ0150
R578	CARBON RES. 1/4W J 330 OHM	RCX4JATZ0331
R578	CARBON RES. 1/6W J 330 OHM	RCX6JATZ0331
R579	CARBON RES. 1/4W J 1K OHM	RCX4JATZ0102
R579	CARBON RES. 1/6W J 1K OHM	RCX6JATZ0102
R581	PCB JUMPER D0.6-P5.0	JW5.0T
R583!	METAL OXIDE FILM RES. 2W J 6.8 OHM	RN026R8ZU001
R583!	METAL OXIDE FILM RES. 2W J 6.8 OHM	RN026R8DP004
R584	CARBON RES. 1/4W J 1K OHM	RCX4JATZ0102
R584	CARBON RES. 1/6W J 1K OHM	RCX6JATZ0102
R585	CARBON RES. 1/4W J 47K OHM	RCX4JATZ0473
R586	CARBON RES. 1/4W J 220K OHM	RCX4JATZ0224
R587	CARBON RES. 1/4W J 56K OHM	RCX4JATZ0563
R588	CARBON RES. 1/4W J 56K OHM	RCX4JATZ0563
R589	CARBON RES. 1/4W J 22K OHM	RCX4JATZ0223
R590	CARBON RES. 1/4W J 12K OHM	RCX4JATZ0123
R591!	CARBON RES. 1/4W J 180K OHM	RCX4JATZ0184
R592!	CARBON RES. 1/4W J 180K OHM	RCX4JATZ0184
R593!	CARBON RES. 1/4W J 100K OHM	RCX4JATZ0104
R594!	CARBON RES. 1/4W J 82K OHM	RCX4JATZ0823
R595	CARBON RES. 1/4W J 1.5K OHM	RCX4JATZ0152
R596	CARBON RES. 1/4W J 100 OHM	RCX4JATZ0101
R596	CARBON RES. 1/6W J 100 OHM	RCX6JATZ0101
R597	CARBON RES. 1/4W J 8.2K OHM	RCX4JATZ0822
R598!	CARBON RES. 1/4W J 47K OHM	RCX4JATZ0473
R599!	CARBON RES. 1/4W J 22K OHM	RCX4JATZ0223
R601	CEMENT RES. 5W K 0.56 OHM	RW05R56DP007
R601	CEMENT RES. 5W K 0.56 OHM	RW05R56PG001
R602	CARBON RES. 1/4W J 820K OHM	RCX4JATZ0824
R603	CARBON RES. 1/4W J 820K OHM	RCX4JATZ0824
R604	CARBON RES. 1/4W J 820K OHM	RCX4JATZ0824
R605	CARBON RES. 1/4W J 820K OHM	RCX4JATZ0824
R611	CARBON RES. 1/4W J 220 OHM	RCX4JATZ0221
R611	CARBON RES. 1/6W J 220 OHM	RCX6JATZ0221
R612	CARBON RES. 1/4W J 220 OHM	RCX4JATZ0221
R612	CARBON RES. 1/6W J 220 OHM	RCX6JATZ0221
R613!	CEMENT RES. 5W K 0.27 OHM	RW05R27DP005
R613!	CEMENT RESISTOR 5W K 0.27 OHM	RW05R27PG001
R614	CARBON RES. 1/4W J 47 OHM	RCX4JATZ0470
R614	CARBON RES. 1/6W J 47 OHM	RCX6JATZ0470
R616	CARBON RES. 1/4W J 10K OHM	RCX4JATZ0103
R617	CARBON RES. 1/4W J 47 OHM	RCX4JATZ0470
R617	CARBON RES. 1/6W J 47 OHM	RCX6JATZ0470
R620	CARBON RES. 1/4W J 100 OHM	RCX4JATZ0101
R620	CARBON RES. 1/6W J 100 OHM	RCX6JATZ0101
R621	CARBON RES. 1/4W J 1.2K OHM	RCX4JATZ0122
R623	CARBON RES. 1/4W J 39 OHM	RCX4JATZ0390
R623	CARBON RES. 1/6W J 39 OHM	RCX6JATZ0390
R624	PCB JUMPER D0.6-P5.0	JW5.0T
R626	CARBON RES. 1/4W J 390 OHM	RCX4JATZ0391
R626	CARBON RES. 1/6W J 390 OHM	RCX6JATZ0391
R642	CARBON RES. 1/4W J 22K OHM	RCX4JATZ0223
R643	CARBON RES. 1/4W J 120K OHM	RCX4JATZ0124
R653	CARBON RES. 1/4W J 18K OHM	RCX4JATZ0183

R654!	CARBON RES. 1/4W J 1.8K OHM	RCX4JATZ0182
R655	CARBON RES. 1/4W J 1K OHM	RCX4JATZ0102
R655	CARBON RES. 1/6W J 1K OHM	RCX6JATZ0102
R656!	CARBON RES. 1/4W J 15K OHM	RCX4JATZ0153
R657!	CARBON RES. 1/4W J 15K OHM	RCX4JATZ0153
R658	CARBON RES. 1/4W J 470K OHM	RCX4JATZ0474
R660	CARBON RES. 1/4W J 1K OHM	RCX4JATZ0102
R660	CARBON RES. 1/6W J 1K OHM	RCX6JATZ0102
R661	CARBON RES. 1/4W J 68K OHM	RCX4JATZ0683
R662!	CARBON RES. 1/4W J 82K OHM	RCX4JATZ0823
R664!	CARBON RES. 1/4W J 12K OHM	RCX4JATZ0123
R665!	CARBON RES. 1/4W J 5.6K OHM	RCX4JATZ0562
R666	METAL RESISTOR 2W J 18K OHM	RN02183ZU001
R666	METAL OXIDE FILM RES. 2W J 18K OHM	RN02183DP004
R667!	CARBON RES. 1/4W J 27K OHM	RCX4JATZ0273
R668!	CARBON RES. 1/4W J 33K OHM	RCX4JATZ0333
R669!	CARBON RES. 1/4W J 27K OHM	RCX4JATZ0273
R670!	CARBON RES. 1/4W J 100K OHM	RCX4JATZ0104
R671	CARBON RES. 1/4W J 3.3K OHM	RCX4JATZ0332
R672	CARBON RES. 1/4W J 3.3K OHM	RCX4JATZ0332
R673	CARBON RES. 1/4W J 100K OHM	RCX4JATZ0104
R675	CARBON RES. 1/4W J 22K OHM	RCX4JATZ0223
R676	CARBON RES. 1/4W J 10K OHM	RCX4JATZ0103
R677	CARBON RES. 1/4W J 68K OHM	RCX4JATZ0683
R678	CARBON RES. 1/4W J 47K OHM	RCX4JATZ0473
R681	CARBON RES. 1/4W J 12 OHM	RCX4JATZ0120
R681	CARBON RES. 1/6W J 12 OHM	RCX6JATZ0120
R682!	METAL OXIDE FILM RES. 1W J 47 OHM	RN01470ZU001
R682!	METAL OXIDE FILM RES. 1W J 47 OHM	RN01470DP003
R683!	METAL OXIDE FILM RES. 1W J 39 OHM	RN01390ZU001
R683!	METAL OXIDE FILM RES. 1W J 39 OHM	RN01390DP003
R684	CARBON RES. 1/4W J 56 OHM	RCX4JATZ0560
R684	CARBON RES. 1/6W J 56 OHM	RCX6JATZ0560
R685	CARBON RES. 1/4W J 56 OHM	RCX4JATZ0560
R685	CARBON RES. 1/6W J 56 OHM	RCX6JATZ0560
R686	CARBON RES. 1/4W J 100 OHM	RCX4JATZ0101
R686	CARBON RES. 1/6W J 100 OHM	RCX6JATZ0101
R687	CARBON RES. 1/4W J 100 OHM	RCX4JATZ0101
R687	CARBON RES. 1/6W J 100 OHM	RCX6JATZ0101
R691	CARBON RES. 1/4W J 15K OHM	RCX4JATZ0153
R696	CARBON RES. 1/4W J 10 OHM	RCX4JATZ0100
R696	CARBON RES. 1/6W J 10 OHM	RCX6JATZ0100
R701	CARBON RES. 1/4W J 75 OHM	RCX4JATZ0750
R701	CARBON RES. 1/6W J 75 OHM	RCX6JATZ0750
R702	PCB JUMPER D0.6-P5.0	JW5.0T
R703	PCB JUMPER D0.6-P5.0	JW5.0T
R711	CARBON RES. 1/4W J 47K OHM	RCX4JATZ0473
R712	CARBON RES. 1/4W J 3.9K OHM	RCX4JATZ0392
R713	CARBON RES. 1/4W J 39K OHM	RCX4JATZ0393
R721	CARBON RES. 1/4W J 47K OHM	RCX4JATZ0473
R722	CARBON RES. 1/4W J 3.9K OHM	RCX4JATZ0392
R723	CARBON RES. 1/4W J 39K OHM	RCX4JATZ0393
R731	CARBON RES. 1/4W J 75 OHM	RCX4JATZ0750
R731	CARBON RES. 1/6W J 75 OHM	RCX6JATZ0750
R732	PCB JUMPER D0.6-P5.0	JW5.0T
R733	CARBON RES. 1/4W J 100 OHM	RCX4JATZ0101
R733	CARBON RES. 1/6W J 100 OHM	RCX6JATZ0101
R741	CARBON RES. 1/4W J 47K OHM	RCX4JATZ0473

R742	CARBON RES. 1/4W J 3.9K OHM	RCX4JATZ0392
R744	CARBON RES. 1/4W J 39K OHM	RCX4JATZ0393
R746	CARBON RES. 1/4W J 47K OHM	RCX4JATZ0473
R747	CARBON RES. 1/4W J 3.9K OHM	RCX4JATZ0392
R749	CARBON RES. 1/4W J 39K OHM	RCX4JATZ0393
R751	CARBON RES. 1/4W J 68 OHM	RCX4JATZ0680
R751	CARBON RES. 1/6W J 68 OHM	RCX6JATZ0680
R752	CARBON RES. 1/4W J 560 OHM	RCX4JATZ0561
R752	CARBON RES. 1/6W J 560 OHM	RCX6JATZ0561
R753	CARBON RES. 1/4W J 560 OHM	RCX4JATZ0561
R753	CARBON RES. 1/6W J 560 OHM	RCX6JATZ0561
R761	CARBON RES. 1/4W J 2.2K OHM	RCX4JATZ0222
R762	CARBON RES. 1/4W J 56K OHM	RCX4JATZ0563
R763	CARBON RES. 1/4W J 820 OHM	RCX4JATZ0821
R763	CARBON RES. 1/6W J 820 OHM	RCX6JATZ0821
R764	CARBON RES. 1/4W J 15K OHM	RCX4JATZ0153
R766	CARBON RES. 1/4W J 2.2K OHM	RCX4JATZ0222
R767	CARBON RES. 1/4W J 56K OHM	RCX4JATZ0563
R768	CARBON RES. 1/4W J 820 OHM	RCX4JATZ0821
R768	CARBON RES. 1/6W J 820 OHM	RCX6JATZ0821
R769	CARBON RES. 1/4W J 15K OHM	RCX4JATZ0153
R771	CARBON RES. 1/4W J 27K OHM	RCX4JATZ0273
R772	CARBON RES. 1/4W J 100 OHM	RCX4JATZ0101
R772	CARBON RES. 1/6W J 100 OHM	RCX6JATZ0101
R773	CARBON RES. 1/4W J 68K OHM	RCX4JATZ0683
R774	CARBON RES. 1/4W J 68K OHM	RCX4JATZ0683
R776	CARBON RES. 1/4W J 27K OHM	RCX4JATZ0273
R777	CARBON RES. 1/4W J 100 OHM	RCX4JATZ0101
R777	CARBON RES. 1/6W J 100 OHM	RCX6JATZ0101
R782	CARBON RES. 1/4W J 330 OHM	RCX4JATZ0331
R782	CARBON RES. 1/6W J 330 OHM	RCX6JATZ0331
R791	CARBON RES. 1/4W J 10K OHM	RCX4JATZ0103
R792	CARBON RES. 1/4W J 10K OHM	RCX4JATZ0103
R801	CARBON RES. 1/2W J 100 OHM	RCX2JZQZ0101
R801	CARBON RES. 1/2W J 100 OHM	RCX2101KA013
R801	CARBON RES. 1/2W J 100 OHM	RCX2JZPZ0101
R802	CARBON RES. 1/2W J 100 OHM	RCX2JZQZ0101
R802	CARBON RES. 1/2W J 100 OHM	RCX2101KA013
R802	CARBON RES. 1/2W J 100 OHM	RCX2JZPZ0101
R803	CARBON RES. 1/4W J 100 OHM	RCX4JATZ0101
R803	CARBON RES. 1/6W J 100 OHM	RCX6JATZ0101
R804	CARBON RES. 1/4W J 100 OHM	RCX4JATZ0101
R804	CARBON RES. 1/6W J 100 OHM	RCX6JATZ0101
R811	PCB JUMPER D0.6-P5.0	JW5.0T
R812	PCB JUMPER D0.6-P5.0	JW5.0T
R817	CARBON RES. 1/4W J 1.8K OHM	RCX4JATZ0182
R818	CARBON RES. 1/4W J 27K OHM	RCX4JATZ0273
R828	CARBON RES. 1/4W J 22K OHM	RCX4JATZ0223
R829	CARBON RES. 1/4W J 1K OHM	RCX4JATZ0102
R829	CARBON RES. 1/6W J 1K OHM	RCX6JATZ0102
R831	CARBON RES. 1/4W J 680 OHM	RCX4JATZ0681
R831	CARBON RES. 1/6W J 680 OHM	RCX6JATZ0681
R832	CARBON RES. 1/4W J 22K OHM	RCX4JATZ0223
R833	CARBON RES. 1/4W J 2.2K OHM	RCX4JATZ0222
R834	CARBON RES. 1/4W J 10K OHM	RCX4JATZ0103
R837	PCB JUMPER D0.6-P5.0	JW5.0T
R838	CARBON RES. 1/4W J 1K OHM	RCX4JATZ0102
R838	CARBON RES. 1/6W J 1K OHM	RCX6JATZ0102

R841	METAL RESISTER. 2W J 2.7 OHM	RN022R7ZU001
R841	METAL OXIDE FILM RES. 2W J 2.7 OHM	RN022R7DP004
R843!	CARBON RES. 1/4W J 2.2K OHM	RCX4JATZ0222
R845	CARBON RES. 1/4W J 2.2K OHM	RCX4JATZ0222
R846	CARBON RES. 1/4W J 2.2K OHM	RCX4JATZ0222
RCV101	REMOCON RECEIVE UNIT MIM-93M8DKL	USESJRSUNT02
RCV101	REMOCON RECEIVE UNIT PIC-26042SR-2	USESJRSKK032
RCV101	REMOCON RECEIVE UNIT PIC-37042SR	USESJRSKK034
RL601!	POWER RELAY SDT-S-112LMR	MRNDC12QN014
RL601!	POWER RELAY RPEF-12-901	MRNDC12KB002
RL601!	RELAY ALKS321	MRNDC12MS013
SA601!	SURGE ABSORBER PVR-07D471KB	NVQZ07D471KB
SA601!	SURGE ABSORBER CNR-07D471K	NVQZR07D471K
SA601!	SURGE ABSORBER AVR-S07D471KAAS	QVQZ0AVRS07D
SA601!	SURGE ABSORBER JVR-07N471K	NVQZVR07N471K
SA601!	VARISTOR ENC471D-07A	QVQZ0471D07A
SF1	SAW FILTER SAFGM45M7VHHZC0B03	FBB456PMR008
SW101	TACT SWITCH SKQSAB	SST0101AL038
SW101	TACT SWITCH KSM0612B	SST0101HH003
SW101	TACT SWITCH SKHHAM	SST0101AL029
SW102	TACT SWITCH SKQSAB	SST0101AL038
SW102	TACT SWITCH KSM0612B	SST0101HH003
SW102	TACT SWITCH SKHHAM	SST0101AL029
SW103	TACT SWITCH SKQSAB	SST0101AL038
SW103	TACT SWITCH KSM0612B	SST0101HH003
SW103	TACT SWITCH SKHHAM	SST0101AL029
SW104	TACT SWITCH SKQSAB	SST0101AL038
SW104	TACT SWITCH KSM0612B	SST0101HH003
SW104	TACT SWITCH SKHHAM	SST0101AL029
SW105	TACT SWITCH SKQSAB	SST0101AL038
SW105	TACT SWITCH KSM0612B	SST0101HH003
SW105	TACT SWITCH SKHHAM	SST0101AL029
SW106	TACT SWITCH SKQSAB	SST0101AL038
SW106	TACT SWITCH KSM0612B	SST0101HH003
SW106	TACT SWITCH SKHHAM	SST0101AL029
T571!	FLYBACK TRANS BSC25-2096S	LTF00CPS2028
T571!	FLYBACK TRANS BSC28-0730	LTF00CPP1011
T571!	FLYBACK TRANSFORMER JF0501-2167	LTF00CPXB030
T572!	HORIZONTAL DRAIVE TRANS CSA-LF161	LTH00CPSA003
T601!	SWITCHING TRANS 02711	LTT00CPKT102
T601!	SWITCHING TRANS CSA-SW0197	LTT00CPSA134
TH551	PCB JUMPER D0.6-P5.0	JW5.0T
TP300	PCB JUMPER D0.6-P12.5	JW12.5T
TP301	PCB JUMPER D0.6-P10.0	JW10.0T
TP302	PCB JUMPER D0.6-P10.0	JW10.0T
TP591	PCB JUMPER D0.6-P5.0	JW5.0T
TP592	PCB JUMPER D0.6-P5.0	JW5.0T
TP601	PCB JUMPER D0.6-P10.0	JW10.0T
TU1	TUNER UNIT TEQH9-001A	UTUNNTUAL032
VR561	CARBON P.O.T. 30K OHM B	VRCB303KA011
VR561	CARBON P.O.T. 30K OHM B	VRCB303HH014
VR562	CARBON P.O.T. 5K OHM B	VRCB502KA011
VR562	CARBON P.O.T. 5K OHM B	VRCB502HH014
VR661	CARBON P.O.T. 50K OHM B	VRCB503KA011
VR661	CARBON P.O.T. 50K OHM B	VRCB503HH014
X301	X'TAL 3.579545 MHZ	FXD355LLN003
X301	X'TAL 3.579545MHZ(30PPM)	FXD355LCHE01
X441	CERAMIC RESONATOR ZTB378F2	FY0374PLN001

X441	CERAMIC RESONATOR CSB378F2	FY0374PMR001
	CRT CBA	-----
BC1501	BEAD INDUCTORS FBR07HA121TB-00	LLBF00ZTU021
C1501	CERAMIC CAP. B K 1000PF/2KV	CCD3DKD0B102
C1501	CERAMIC CAP. B K 1000PF/2KV	CCD3DKP0B102
C1501	CERAMIC CAP. 1000PF/2KV	CA3D102PAN04
C1502	ELECTROLYTIC CAP. 47UF/16V M	CE1CMASLT470
C1502	ELECTROLYTIC CAP. 47UF/16V M	CE1CMASDL470
C1511	CERAMIC CAP.(AX) B K 270PF/50V	CCA1JKT0B271
C1521	CERAMIC CAP.(AX) B K 270PF/50V	CCA1JKT0B271
C1531	CERAMIC CAP.(AX) B K 270PF/50V	CCA1JKT0B271
CN1501	PIN CONNECTOR 005P-5100	JTEA001TG001
JK1501!	CRT SOCKET ISHS40ST	JSCC290PK006
JK1501!	CRT SOCKET HPS0521-012212	JSCC290HD012
L1511	PCB JUMPER D0.6-P5.0	JW5.0T
L1521	PCB JUMPER D0.6-P5.0	JW5.0T
L1531	PCB JUMPER D0.6-P5.0	JW5.0T
Q1512	TRANSISTOR KTC3503Y	NQWY0KTC3503
Q1512	TRANSISTOR 2SC3619	QQ9Z02SC3619
Q1522	TRANSISTOR KTC3503Y	NQWY0KTC3503
Q1522	TRANSISTOR 2SC3619	QQ9Z02SC3619
Q1532	TRANSISTOR KTC3503Y	NQWY0KTC3503
Q1532	TRANSISTOR 2SC3619	QQ9Z02SC3619
R1510	METAL RESISTOR 3W J 10K OHM	RN03103ZU001
R1510	FIXED METAL OXIDE FILM RES. 3W J 10K OHM	RN03103DP005
R1511	CARBON RES. 1/4W J 1.5K OHM	RCX4JATZ0152
R1512	CARBON RES. 1/4W J 1.5K OHM	RCX4JATZ0152
R1515	CARBON RES. 1/4W J 2.7K OHM	RCX4JATZ0272
R1518	CARBON RES. 1/4W J 330 OHM	RCX4JATZ0331
R1518	CARBON RES. 1/6W J 330 OHM	RCX6JATZ0331
R1519	CARBON RES. 1/4W J 100 OHM	RCX4JATZ0101
R1519	CARBON RES. 1/6W J 100 OHM	RCX6JATZ0101
R1520	METAL RESISTOR 3W J 10K OHM	RN03103ZU001
R1520	FIXED METAL OXIDE FILM RES. 3W J 10K OHM	RN03103DP005
R1521	CARBON RES. 1/4W J 1.5K OHM	RCX4JATZ0152
R1522	CARBON RES. 1/4W J 1.5K OHM	RCX4JATZ0152
R1525	CARBON RES. 1/4W J 2.7K OHM	RCX4JATZ0272
R1528	CARBON RES. 1/4W J 330 OHM	RCX4JATZ0331
R1528	CARBON RES. 1/6W J 330 OHM	RCX6JATZ0331
R1529	CARBON RES. 1/4W J 100 OHM	RCX4JATZ0101
R1529	CARBON RES. 1/6W J 100 OHM	RCX6JATZ0101
R1530	METAL RESISTOR 3W J 10K OHM	RN03103ZU001
R1530	FIXED METAL OXIDE FILM RES. 3W J 10K OHM	RN03103DP005
R1531	CARBON RES. 1/4W J 1.5K OHM	RCX4JATZ0152
R1532	CARBON RES. 1/4W J 1.5K OHM	RCX4JATZ0152
R1535	CARBON RES. 1/4W J 2.7K OHM	RCX4JATZ0272
R1538	CARBON RES. 1/4W J 330 OHM	RCX4JATZ0331
R1538	CARBON RES. 1/6W J 330 OHM	RCX6JATZ0331
R1539	CARBON RES. 1/4W J 100 OHM	RCX4JATZ0101
R1539	CARBON RES. 1/6W J 100 OHM	RCX6JATZ0101
R1541	PCB JUMPER D0.6-P5.0	JW5.0T
R1542	PCB JUMPER D0.6-P5.0	JW5.0T
R1543	PCB JUMPER D0.6-P5.0	JW5.0T
TP1501	PCB JUMPER D0.6-P10.0	JW10.0T
TP1502	PCB JUMPER D0.6-P10.0	JW10.0T
	JACK CBA	0ESA05432

C6427TD (L6603CD)

CN1791	CONECTOR, 8P(2.0MM PITCH)TKX-P08P-C1	J3TXC08TG001
JK1791	Y/C JACK 1P(SW) MDC-070V1-A	JYEL040LY002
R1791	CARBON RES. 1/4W J 82 OHM	RCX4JATZ0820
R1791	CARBON RES. 1/6W J 82 OHM	RCX6JATZ0820
R1794	CARBON RES. 1/4W J 330 OHM	RCX4JATZ0331
R1794	CARBON RES. 1/6W J 330 OHM	RCX6JATZ0331
R1796	CARBON RES. 1/4W J 68 OHM	RCX4JATZ0680
R1796	CARBON RES. 1/6W J 68 OHM	RCX6JATZ0680

C6427TD

L6603CD